

H₂

at Scale:

Deeply Decarbonizing
our Energy System

Touch Screen Presentation at AMR

Wardman Park
Marriott
June 6–10, 2016

H₂ at Scale: Deeply Decarbonizing our Energy System

What is Hydrogen at Scale?

Why is it needed?

Why now/today?

What can it accomplish?

How will it be accomplished?

Who is the team?

Why national labs along with industry?

What does success look like?

Additional content/backup slides

What is H₂@Scale?

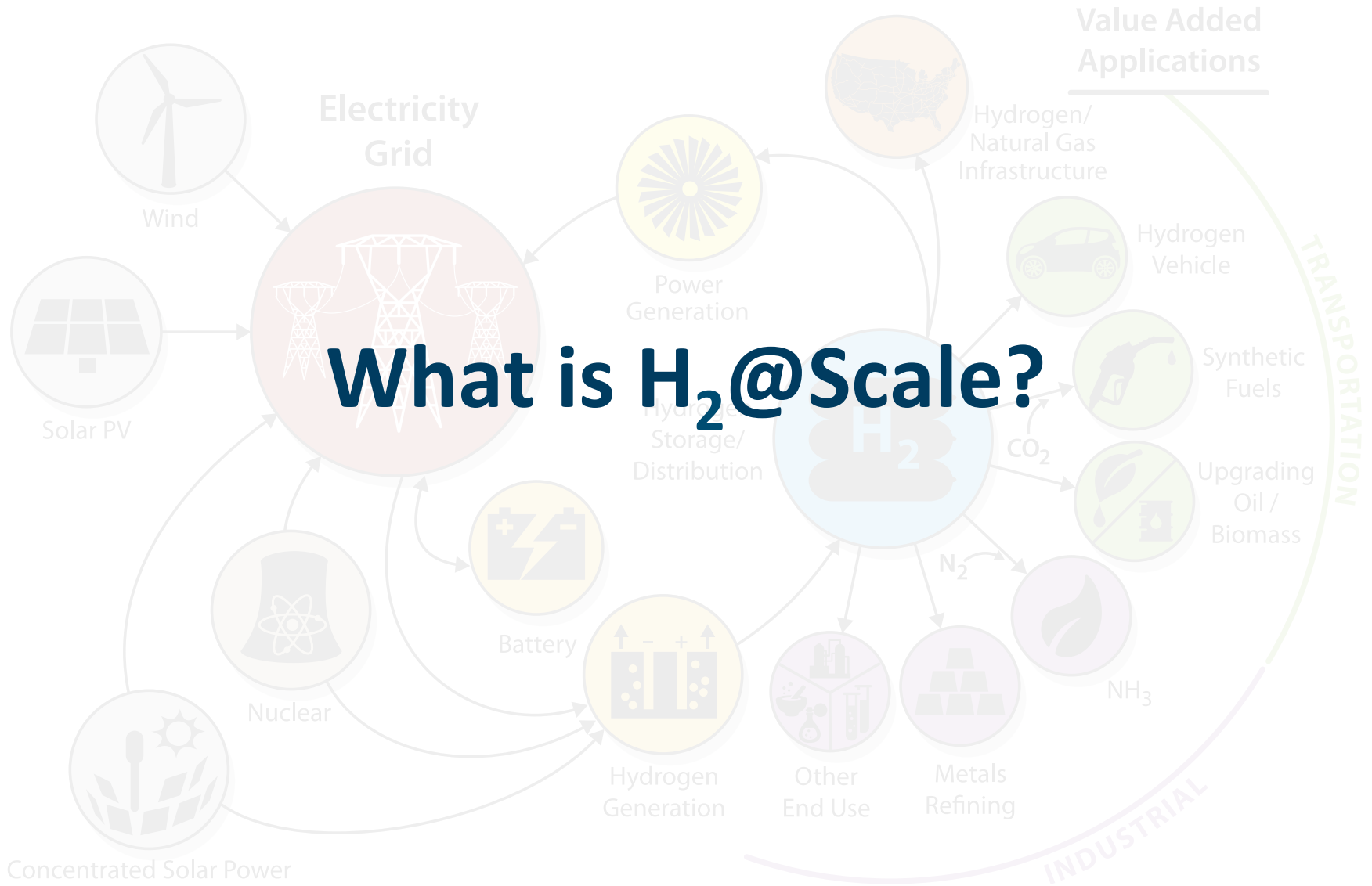

Conceptual H₂ at Scale Energy System*

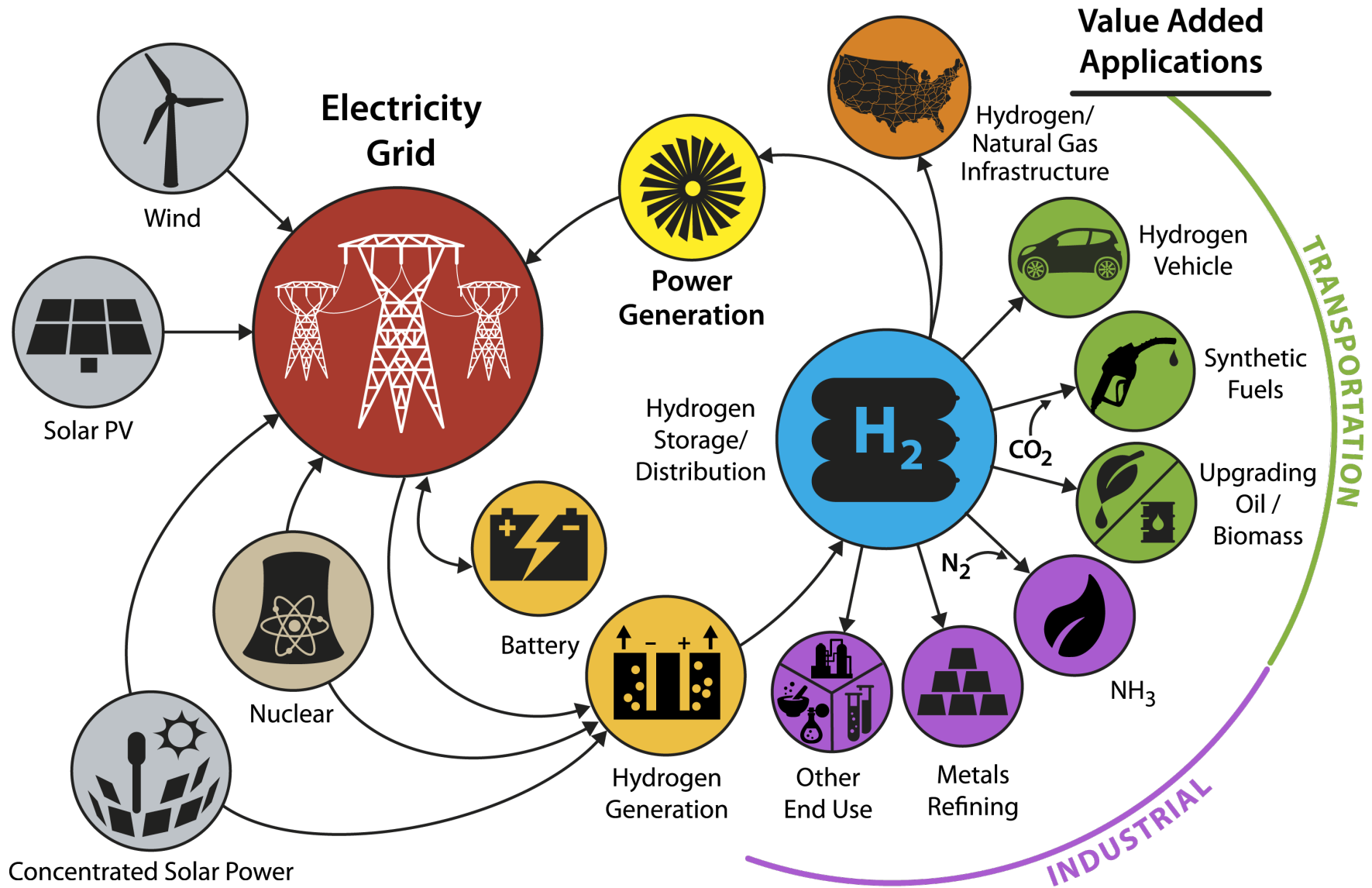

*Illustrative example, not comprehensive



Why?.....Our Cities/Energy System



**need deep
decarbonization**

Decreases all U.S. carbon emissions by about half (2050)

Significantly contributing to administration goal of 83% reduction of GHG emissions by 2050

— PRESIDENT OBAMA'S PLAN TO —
ADDRESS CLIMATE CHANGE

✓ Reduce carbon pollution from power plants and build cars that burn less fuel.

Energy System Challenges

- **Multi-sector requirements**

- Transportation
- Industrial
- Grid

Over half of U.S. CO₂ emissions come from the industrial and transportation sectors

- **Renewable challenges**

- Variable
- Concurrent generation

Denholm et al. 2008

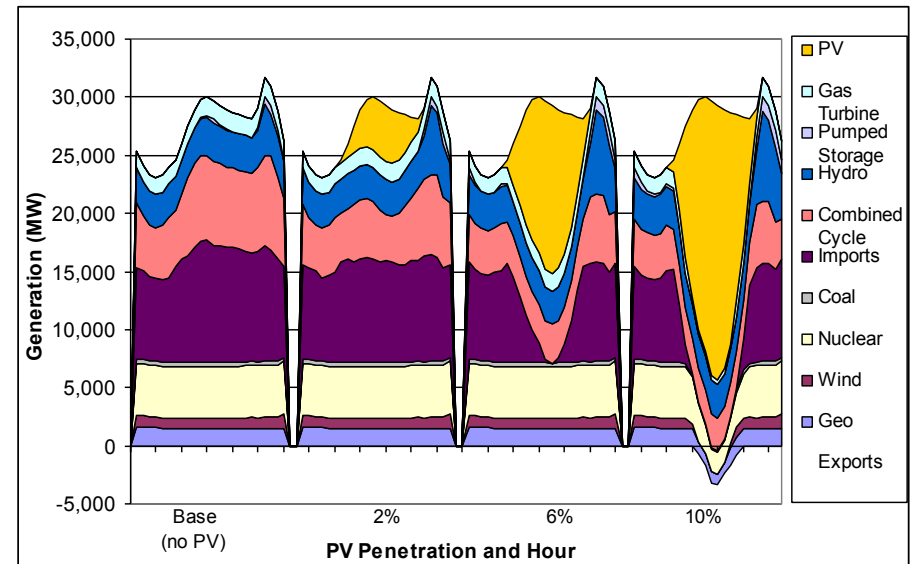

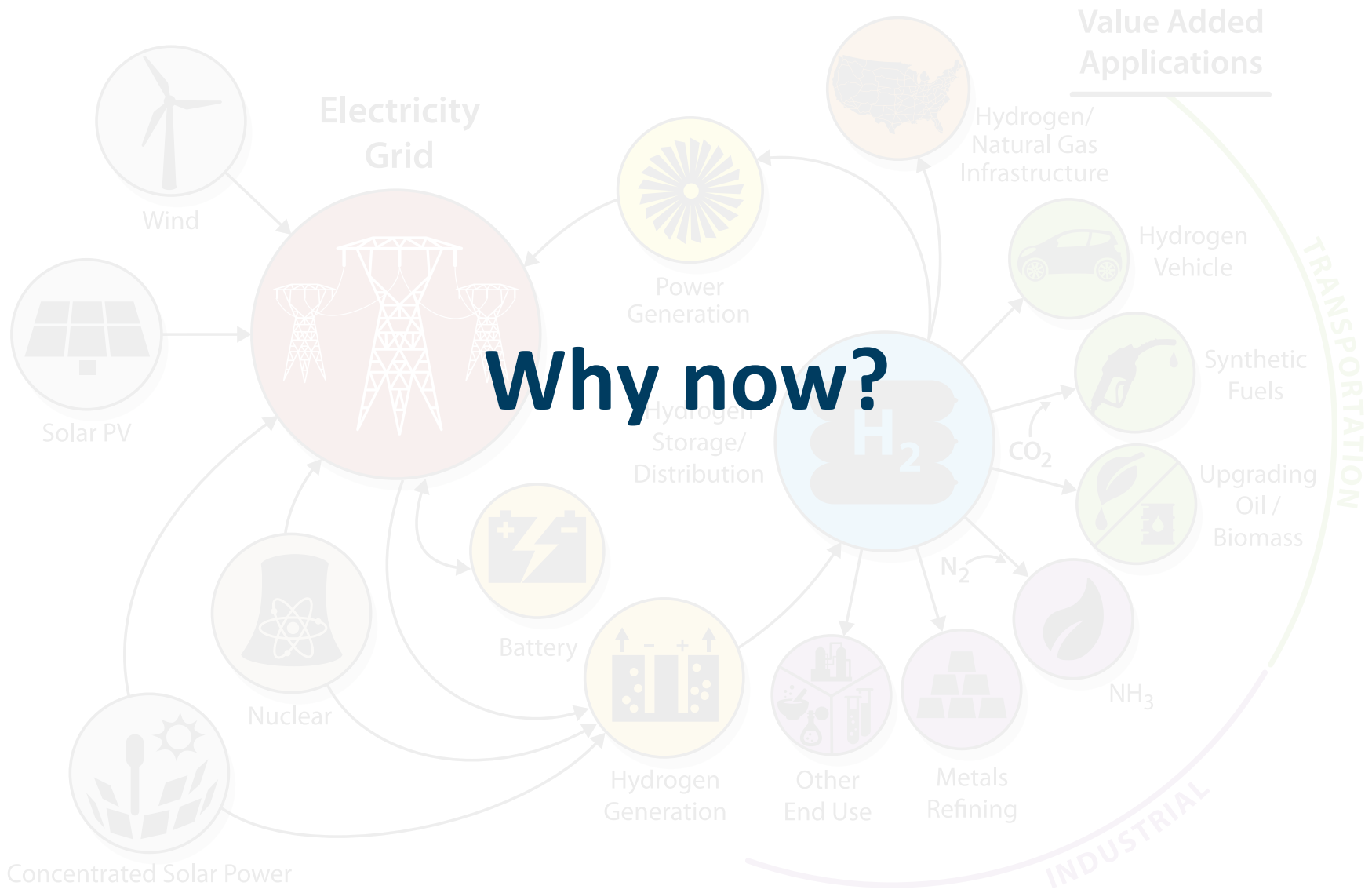

Motivation – Major Administration Energy Goals

1. Reduce GHG emissions by 17% by 2020, 26-28% by 2025 and 83% by 2050 from 2005 baseline Climate Action Plan



2. Reduce net oil imports by half by 2020 from a 2008 baseline Blueprint Secure



3. Double energy productivity by 2030 Department of Energy

4. By 2035, generate 80% of electricity from a diverse set of clean energy resources Blueprint Secure Energy Future



5. Reduce CO₂ emissions by 3 billion metric tons cumulatively by 2030 through efficiency standards set between 2009 and 2016 CAP Progress Report

H₂ at Scale strongly impacts 1 and 4, also impacts 2.

Clean Power Plan
reduce carbon dioxide
emissions by 32% by

President's Climate Action Plan
80% reduction in transportation
GHG by 2050

What has changed, is changing, or will
change that has an impact

Renewable Energy Standards
37 states with renewable
portfolio standards or goals

Growing Renewable Energy Penetration
Since 2008, US solar >20x increase,
wind >3x increase.
Other countries >30% total RE penetration.

Carbon-Free Electricity Prices

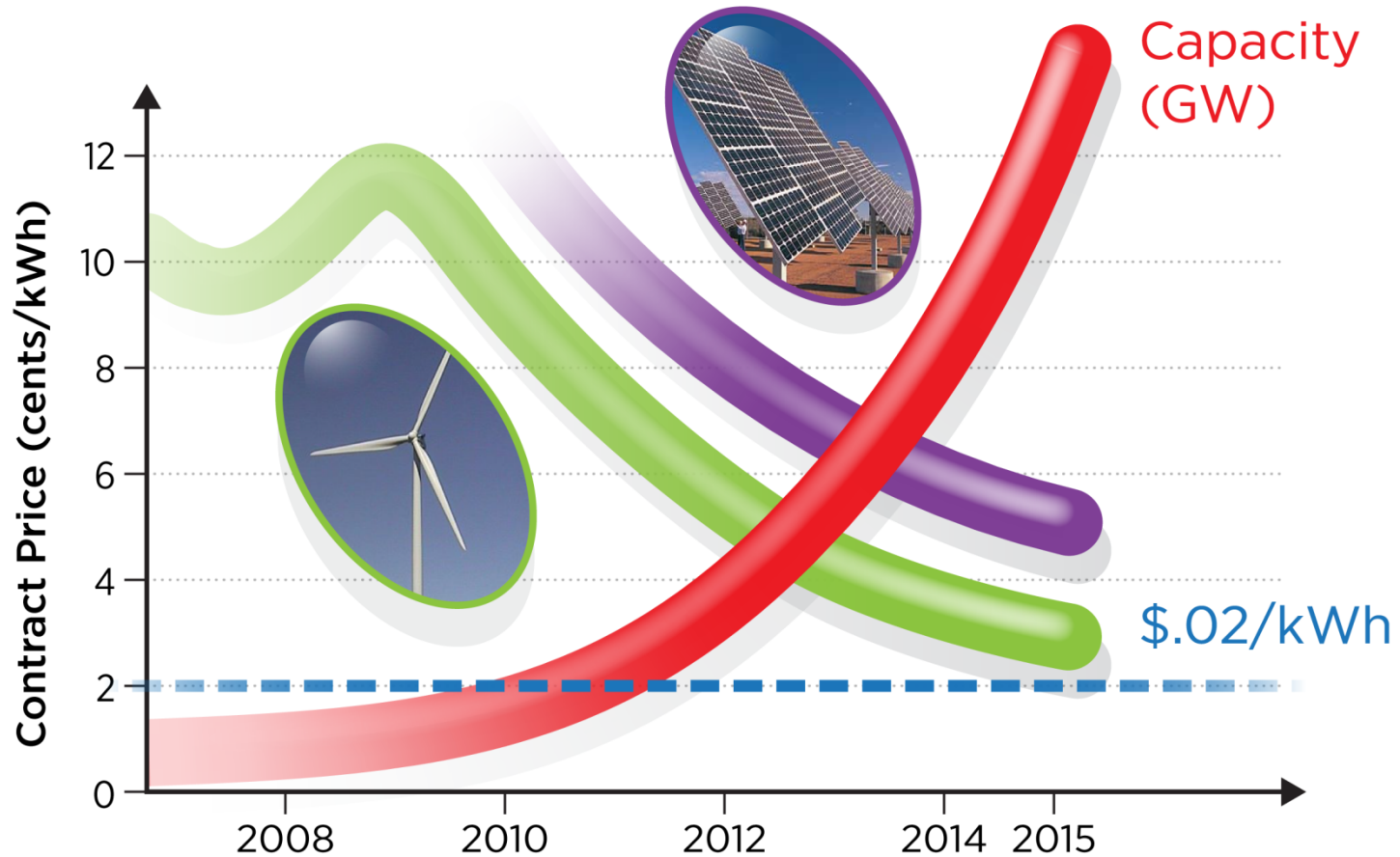

Source: (Arun Majumdar) 1. DOE EERE Sunshot Q1'15 Report, 2. DOE EERE Wind Report, 2015

Limitations of Variable Inputs

Denholm, P.; M. O'Connell; G. Brinkman; J. Jorgenson (2015) Overgeneration from Solar Energy in California: A Field Guide to the Duck Chart. NREL/TP-6A20-65023

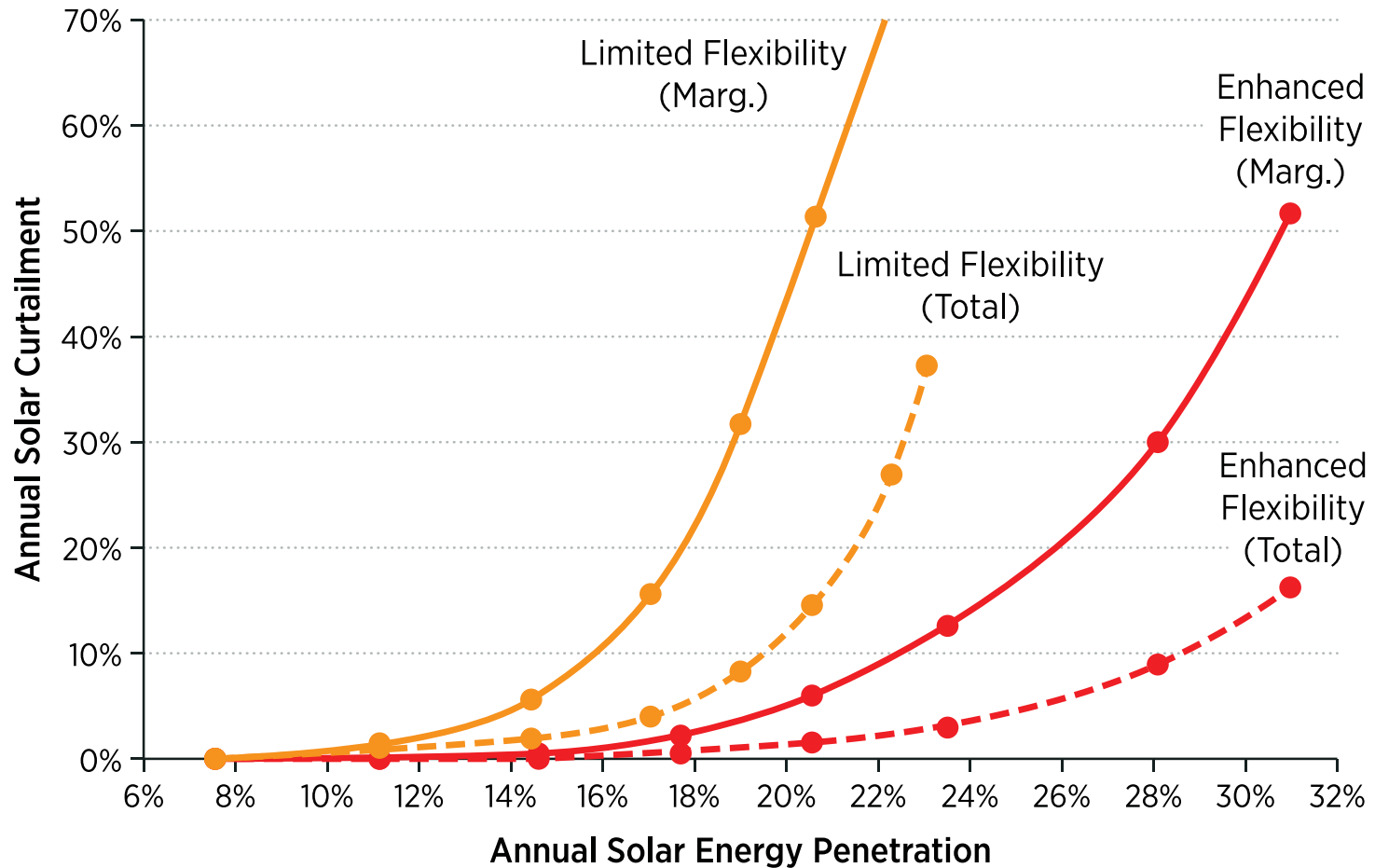

Curtailment will lead to an abundance of low value electrons, and we need solutions that will service our multi-sector demands

Example: Germany Already Limiting RE Penetration Rate

Share of Renewable Electricity
at Brut Electricity Consumption (Energy) in Germany

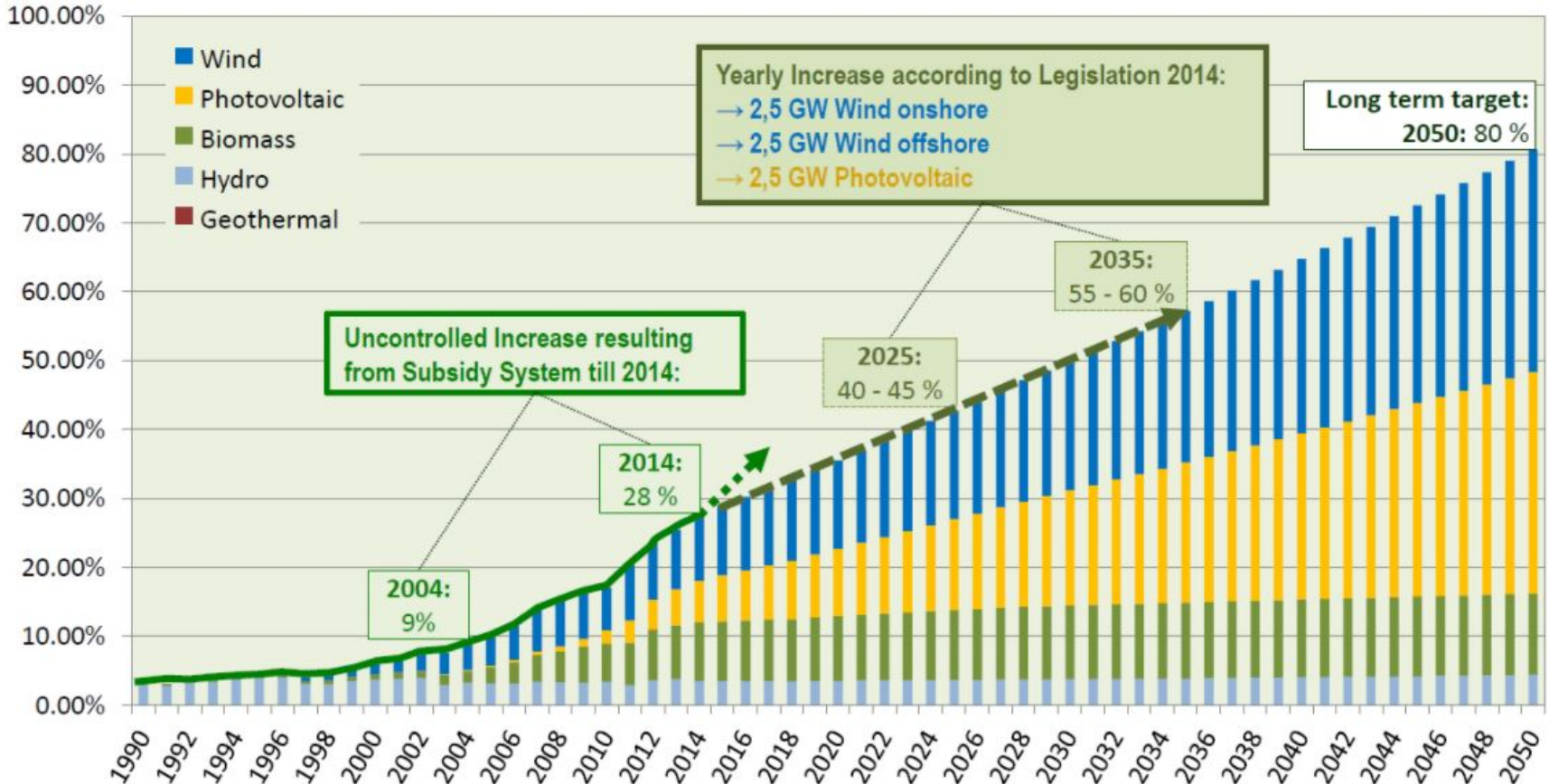

Source: BMWI

What can it accomplish?



Current Energy Flow

Estimated U.S. Energy Use in 2014: ~98.3 Quads

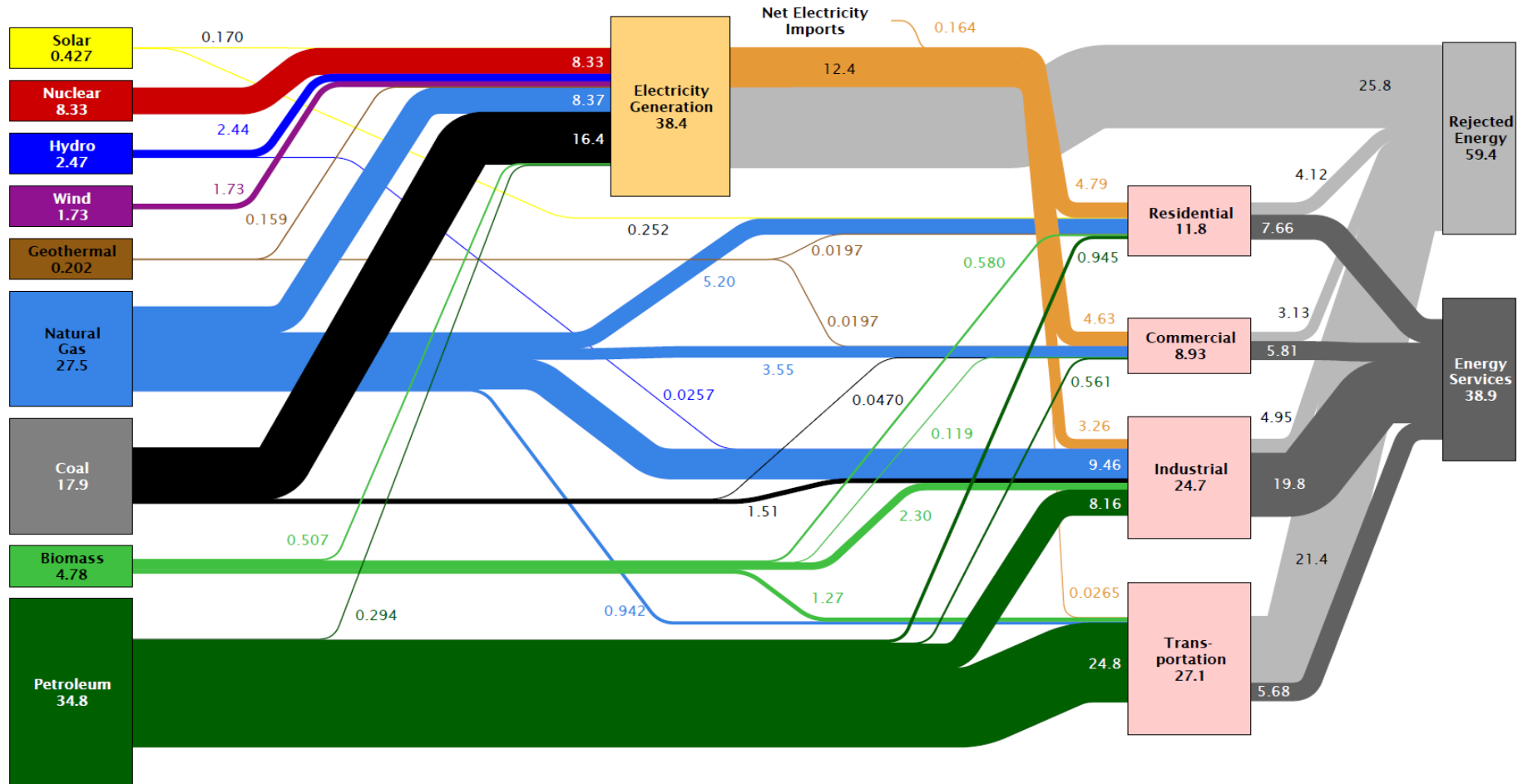

Source: LLNL 2015. Data is based on DOE/EIA-0035(2015-03), March, 2014. If this information or a reproduction of it is used, credit must be given to the Lawrence Livermore National Laboratory and the Department of Energy, under whose auspices the work was performed. Distributed electricity represents only retail electricity sales and does not include self-generation. EIA reports consumption of renewable resources (i.e., hydro, wind, geothermal and solar) for electricity in BTU-equivalent values by assuming a typical fossil fuel plant "heat rate." The efficiency of electricity production is calculated as the total retail electricity delivered divided by the primary energy input into electricity generation. End use efficiency is estimated as 65% for the residential and commercial sectors 80% for the industrial sector, and 21% for the transportation sector. Totals may not equal sum of components due to independent rounding. LLNL-MI-410527

Current Energy Flow – w/Hydrogen

2014 Estimated U.S. Annual Energy Use - Hydrogen Contributions Broken Out ~ 98 Quads

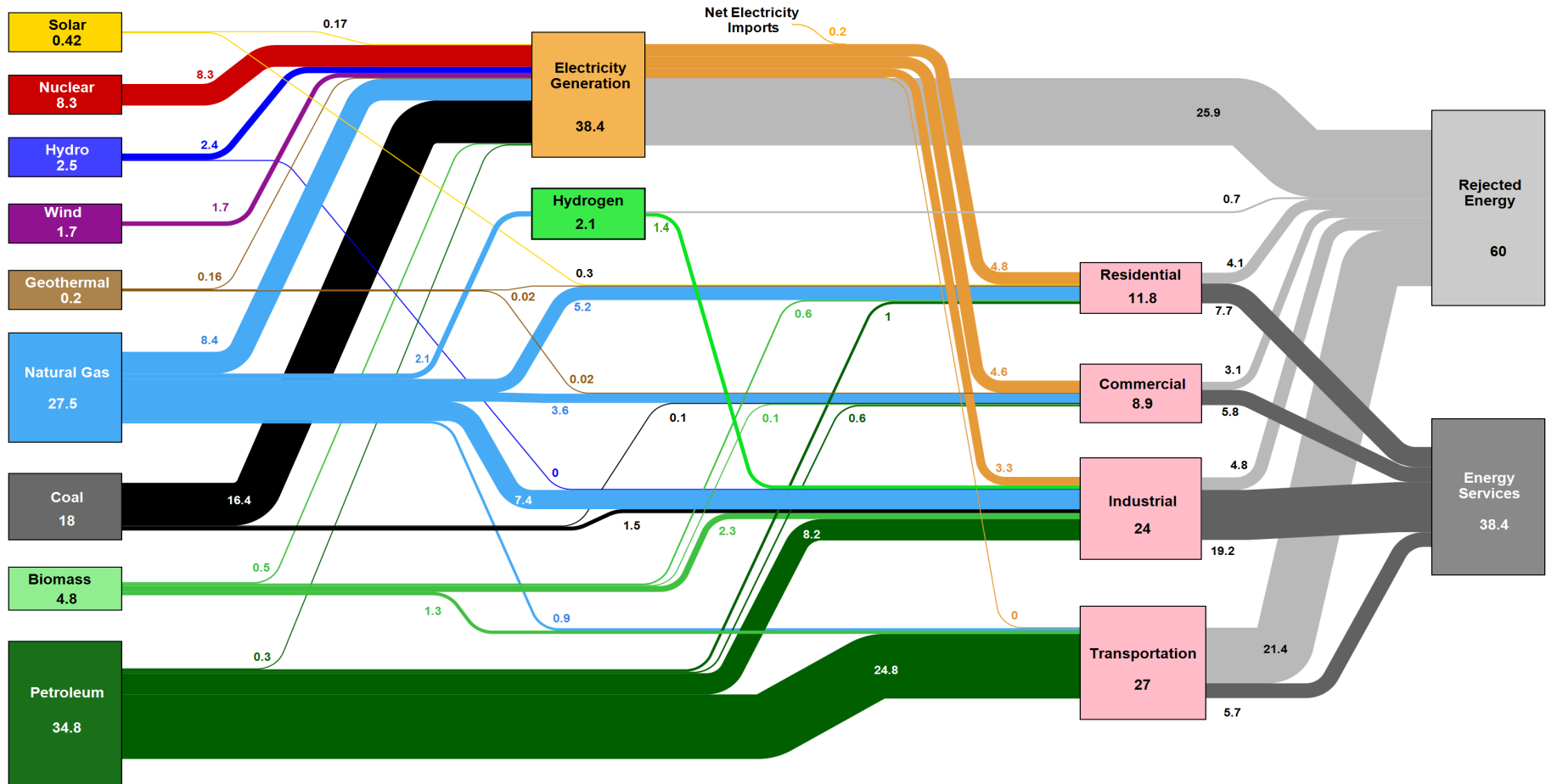

Source: LLNL September 2015. Data is based on DOE/EIA-0035 (2015-03) and Annual Energy Outlook DOE/EIA-0383 (2014). If this information or a reproduction of it is used, credit must be given to the Lawrence Livermore National Laboratory and the Department of Energy, under whose auspices the work was performed. Distributed electricity represents only retail electricity sales and does not include self-generation. EIA reports consumption of renewable resources (i.e., hydro, wind, geothermal and solar) for electricity in BTU-equivalent values by assuming a typical fossil fuel plant "heat rate". The efficiency of electricity production is calculated as the total retail electricity delivered divided by the primary energy input into electricity generation. End use efficiency is estimated as 65% for the residential sector, 65% for the commercial sector, 80% for the industrial sector, and 21% for the transportation sector. Totals may not equal sum of components due to independent rounding. LLNL-MI-676987

Please note, all results presented on this slide are PRELIMINARY and may be subject to corrections and/or changes. A cursory analysis was performed using available information and estimates of impacts due to changes to the modeled energy systems.

Energy Flow 2040 Business as Usual

2040 EIA AEO Estimated U.S. Annual Energy Use - Hydrogen Contributions Broken Out ~ 108 Quads

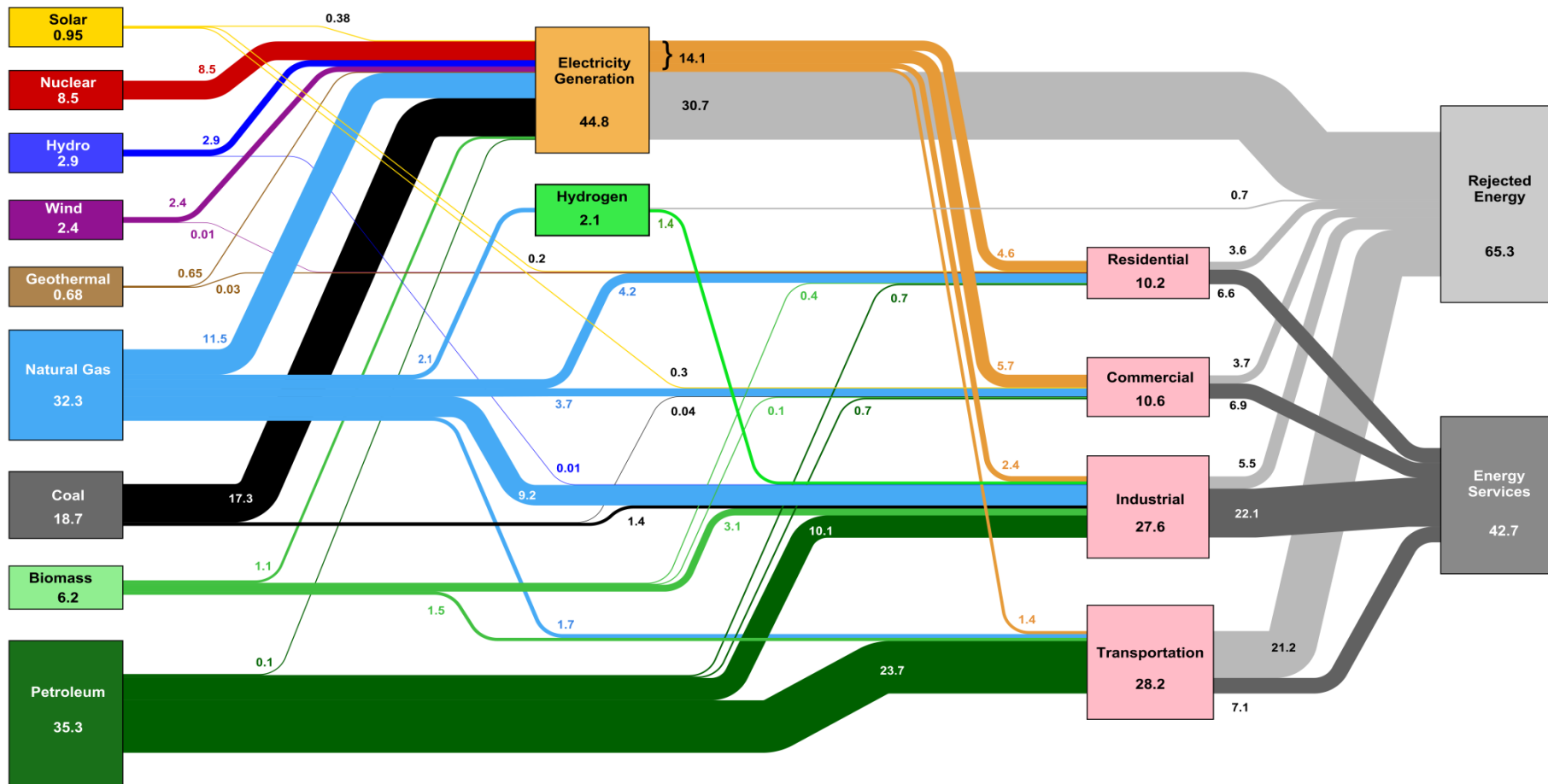

Source: LLNL March 2016. Data is based on DOE/EIA-0035(2015-03) and Annual Energy Outlook DOE/EIA-0383(2014). If this information or a reproduction of it is used, credit must be given to the Lawrence Livermore National Laboratory and the Department of Energy, under whose auspices the work was performed. Distributed electricity represents only retail electricity sales and does not include self-generation. EIA reports consumption of renewable resources (i.e., hydro, wind, geothermal and solar) for electricity in BTU-equivalent values by assuming a typical fossil fuel plant "heat rate". The efficiency of electricity production is calculated as the total retail electricity delivered divided by the primary energy input into electricity generation. End use efficiency is estimated as 65% for the residential sector, 65% for the commercial sector, 80% for the industrial sector, and 21% for the transportation sector. Totals may not equal sum of components due to independent rounding. LLNL-MI-676987

Please note, all results presented on this slide are PRELIMINARY and may be subject to corrections and/or changes. A cursory analysis was performed using available information and estimates of impacts due to changes to the modeled energy systems.

Energy Flows – 2050 High RE/H₂

2050 Estimated U.S. Annual Energy Use with High Hydrogen Contributions Broken Out ~ 77 Quads

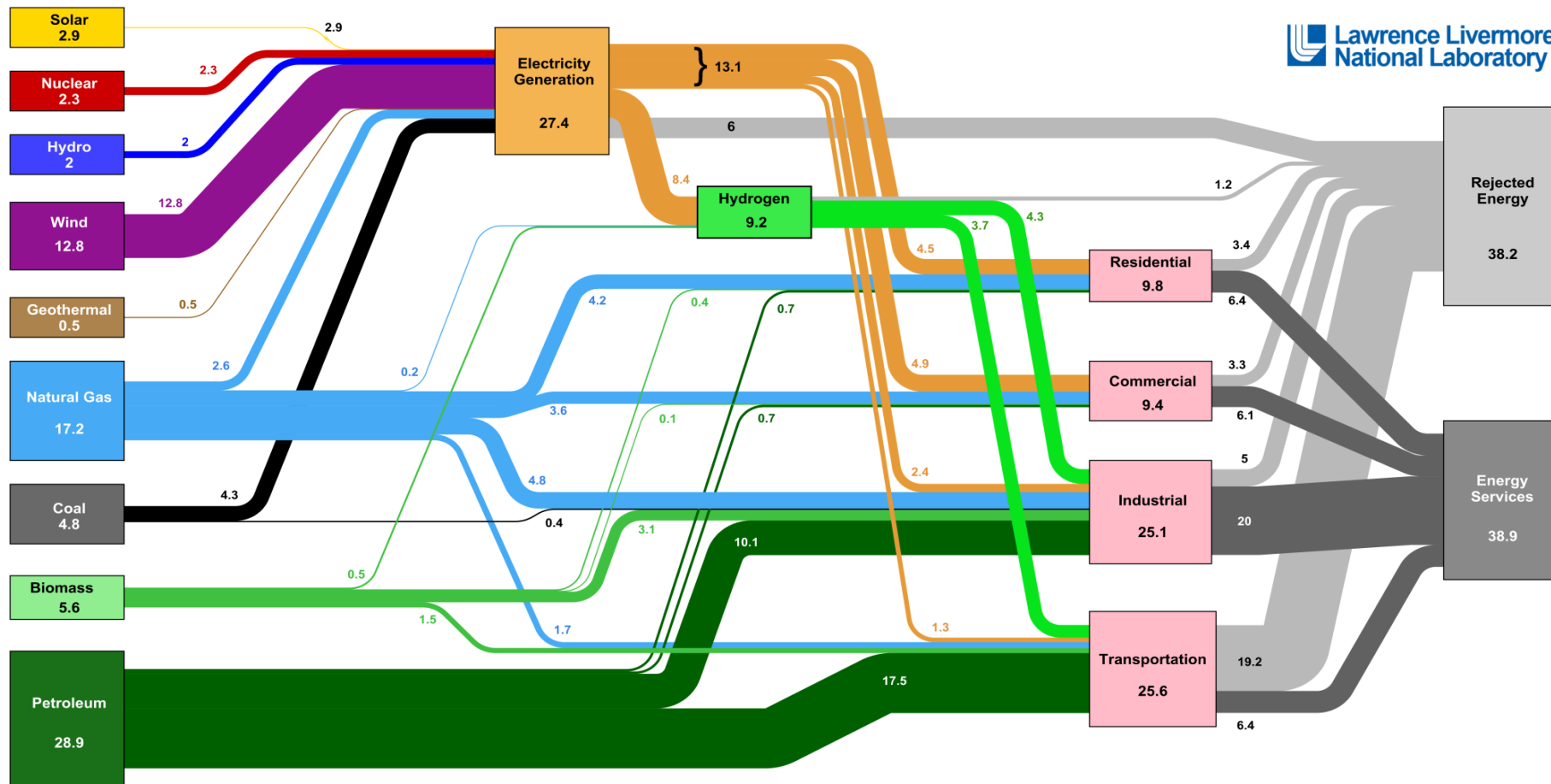

Source: LLNL September 2015. Data is based on High Hydrogen Estimations and DOE/EIA-0383(2014). If this information or a reproduction of it is used, credit must be given to the Lawrence Livermore National Laboratory and the Department of Energy, under whose auspices the work was performed. Distributed electricity represents only retail electricity sales and does not include self-generation. EIA reports consumption of renewable resources (i.e., hydro, wind, geothermal and solar) for electricity in BTU-equivalent values by assuming a typical fossil fuel plant "heat rate". The efficiency of electricity production is calculated as the total retail electricity delivered divided by the primary energy input into electricity generation. End use efficiency is estimated as 65% for the residential sector, 65% for the commercial sector, 80% for the industrial sector, and 21% for the transportation sector. Totals may not equal sum of components due to independent rounding. LLNL-MI-676987

Please note, all results presented on this slide are PRELIMINARY and may be subject to corrections and/or changes. A cursory analysis was performed using available information and estimates of impacts due to changes to the modeled energy systems.



BAU (Business As Usual) vs. High H₂ – Energy Difference*

Energy Use difference between 2050 high-H₂ and AEO 2040 scenarios (Quad Btu)

Red flows represent a reduction (between scenarios)
Black flows represent an increase (between scenarios)

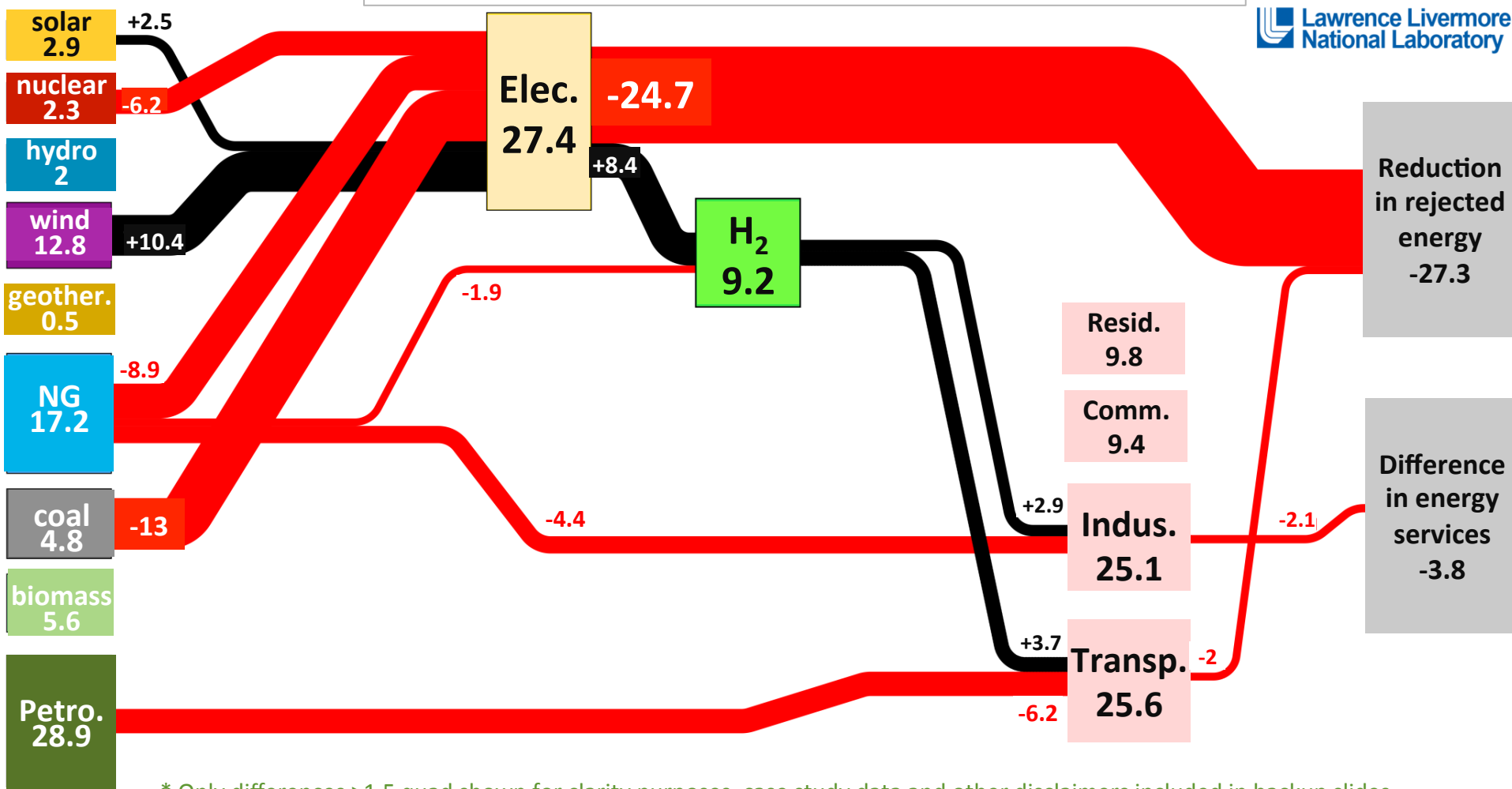

* Only differences >1.5 quad shown for clarity purposes, case study data and other disclaimers included in backup slides

BAU (Business As Usual) vs. High H₂ – CO₂ Difference*

Emissions difference between 2050 high-H₂ and AEO 2040 scenarios (million MT)

Red flows represent a reduction (between scenarios)

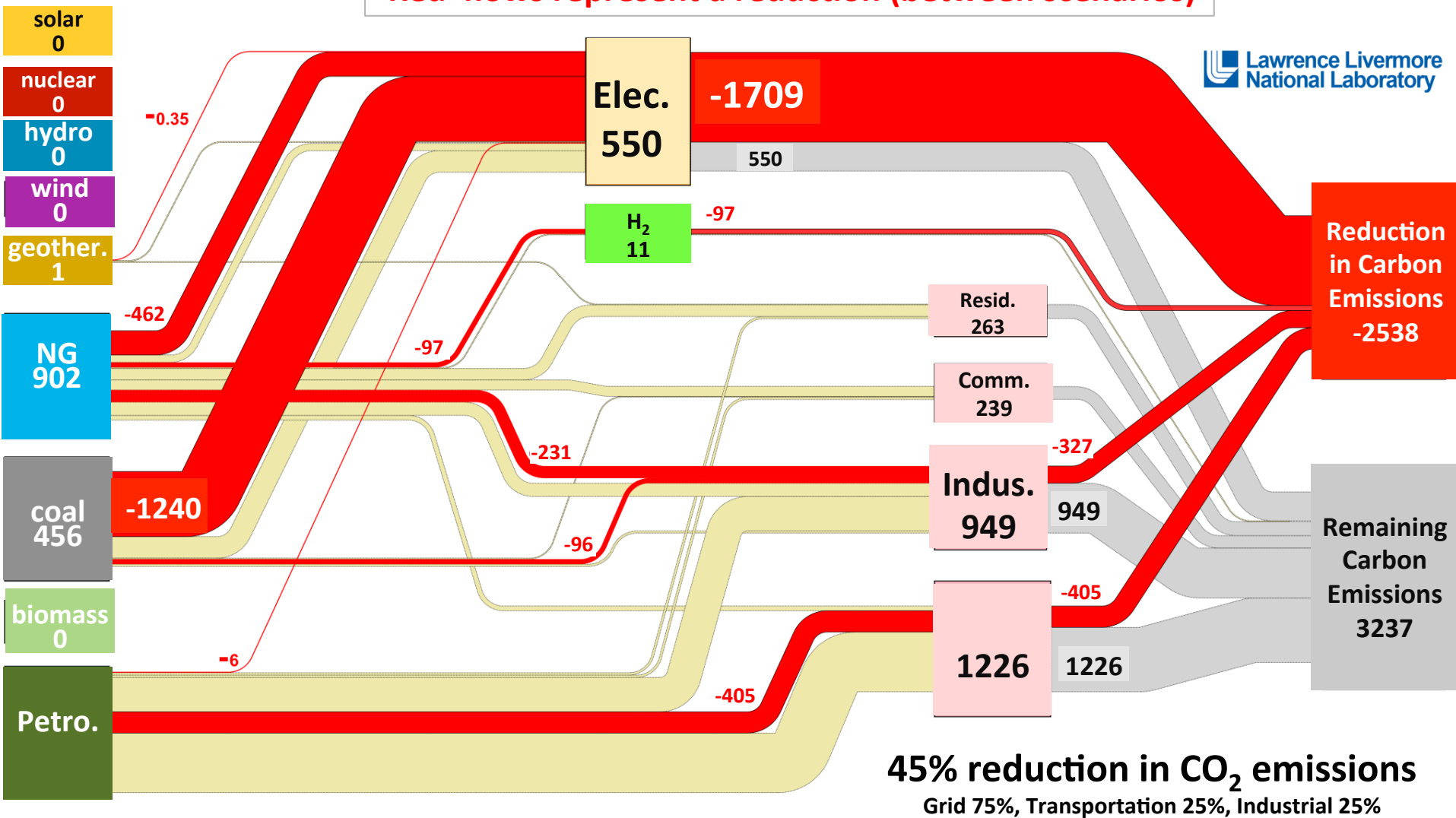

Improving the Economics of Renewable H₂

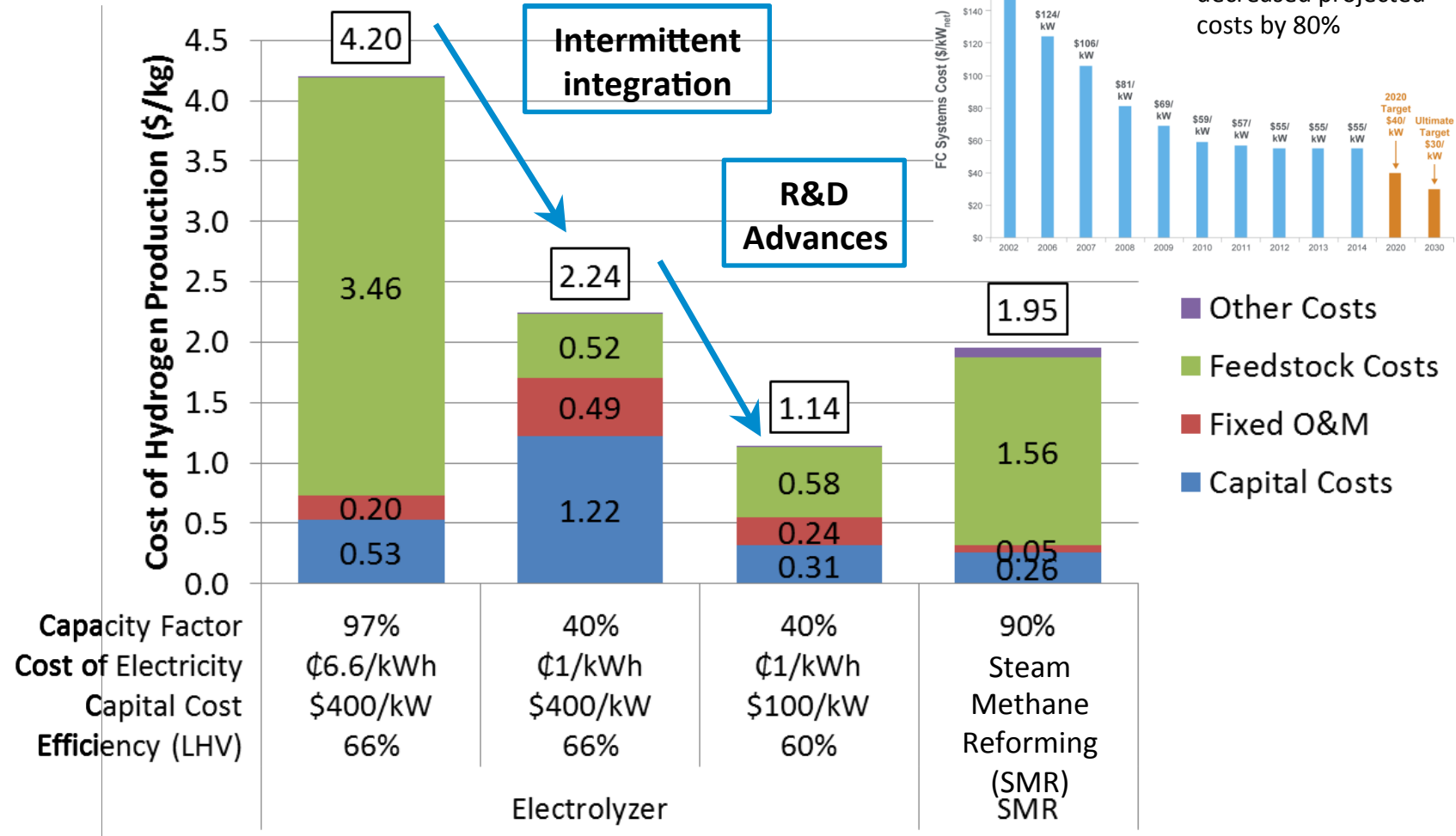

How will it be accomplished?



Conceptual H₂ at Scale Energy System*

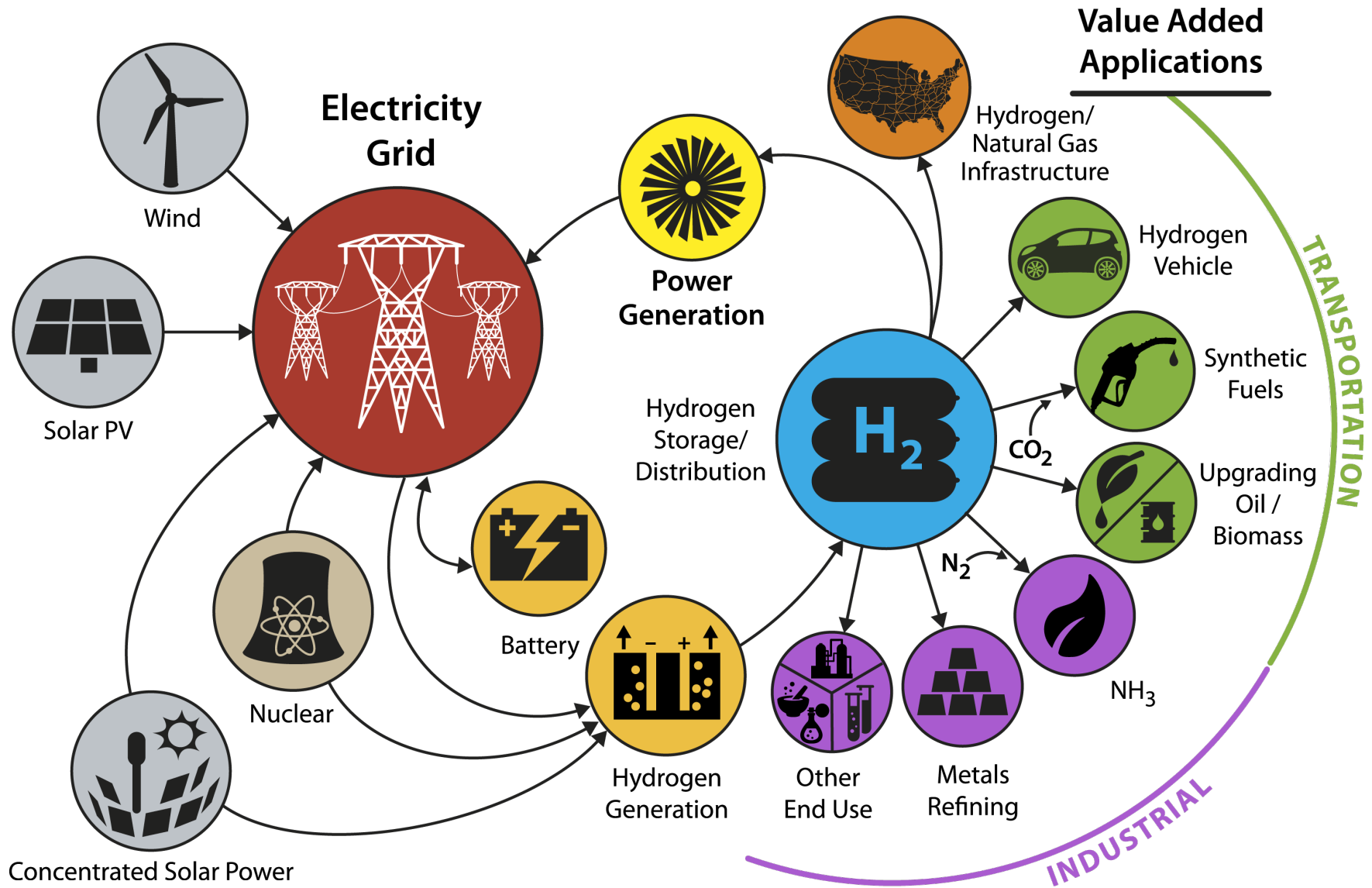

*Illustrative example, not comprehensive

What is Needed to Achieve H₂ at Scale?

Low and High Temperature H₂ Generation

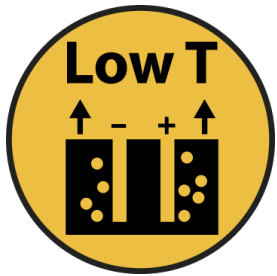

Development of **low cost, durable, and intermittent H₂ generation.**

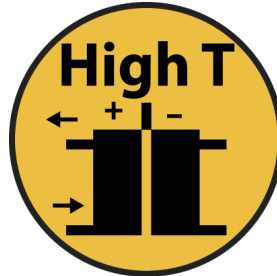

Development of **thermally integrated, low cost, durable, and variable H₂ generation.**

H₂ Storage and Distribution

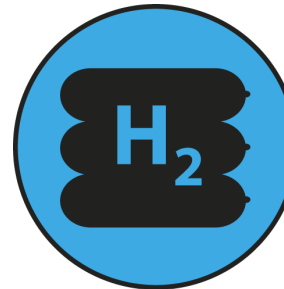

Development of **safe, reliable, and economic storage and distribution systems.**

H₂ Utilization

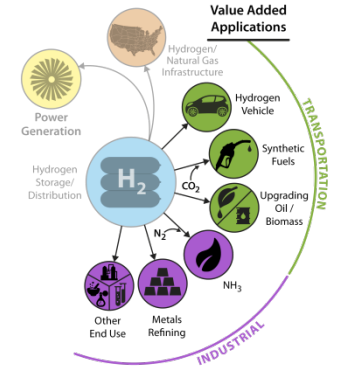

H₂ as game-changing energy carrier, revolutionizing energy sectors.

Analysis

Foundational Science

Future Electrical Grid

H₂ at Scale Value Summary

- Reducing emissions across sectors (GHG, criteria pollutants)
- Support needs of dynamic, variable power systems (dispatchable, scalable, 'one-way' storage)

Unique potential of H₂ to positively impact all these areas

- Other benefits
 - Energy security (diversity/resiliency/domestic)
 - Manufacturing competitiveness/job creation
 - Decreased water requirements

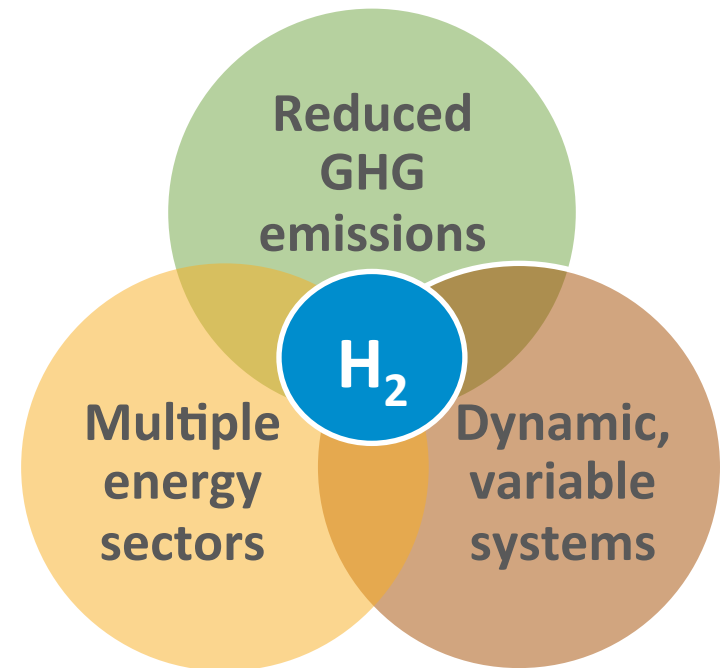

Who is the team?



H₂ at Scale Big Idea Team

Steering Committee:

Bryan Pivovar (lead, NREL), Amgad Elgowainy (ANL), Richard Boardman (INL), Adam Weber (LBNL), Salvador Aceves (LLNL), Rod Borup (LANL), Mark Ruth (NREL), David Wood (ORNL), Jamie Holladay (PNNL), Art Pontau (SNL), Don Anton (SRNL), Mark Hartney (SLAC), Vitalij Pecharsky (Ames); Alex Harris (BNL); Geo (NREL)

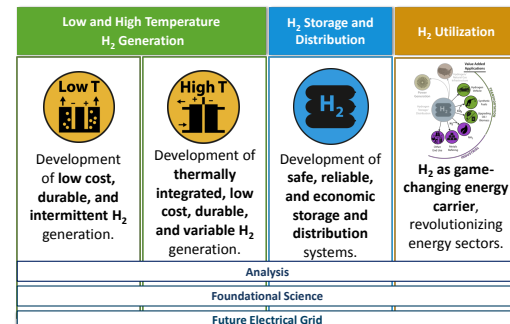

Low T Generation:

Rod Borup (lead, LANL); Jamie Holladay (co-lead, PNNL); Christopher San Marchi (SNL); Hector Colon Mercado (SRNL); Kevin Harrison (NREL); Ted Krause (ANL); Adam Weber (LBNL); David Wood (ORNL)

High T Generation:

Jamie Holladay (lead, PNNL); Jim O'Brien (INL); Tony McDaniel (SNL); Ting He (INL); Mike Penev (NREL); Bill Summers (SRNL); Maximilian Gorenssek (SRNL); Jeffery Stevenson (PNNL); Mo Khaleel (ORNL)

Storage and Distribution:

Don Anton (lead, SRNL); Chris San Marchi (SNL); Kriston Brooks (PNNL); Troy Semelsberger (LANL); Salvador Aceves (LLNL); Thomas Gennett (NREL); Jeff Long (LBNL); Mark Allendorf (SNL); Mark Bowden PNNL; Tom Autrey PNNL

Utilization:

Richard Boardman (lead, INL); Don Anton (SRNL); Amgad Elgowainy (ANL); Bob Hwang (SNL); Mark Bearden (PNNL); Mark Ruth (NREL); Colin McMillan (NREL); Ting He (INL); Michael Glazoff (INL); Art Pontau (SNL); Kriston Brooks (PNNL); Jamie Holladay (PNNL); Christopher San Marchi (SNL); Mary Bidy (NREL)

Future Electric Grid:

Art Pontau (lead, SNL); Art Anderson (NREL); Bryan Hannegan (NREL); Chris San Marchi (SNL); Charles Hanley (SNL); Michael Kintner-Meyer (PNNL); Jamie Holladay (PNNL); Rob Hovsopian (INL)

Foundational Science:

Adam Weber (lead, LBNL); Voja Stamekovic (ANL); Nenad Markovic (ANL); Frances Houle (LBNL); Morris Bullock (PNNL); Aaron Appel (PNNL); Wendy Shaw (PNNL); Tom Jaramillo (SLAC); Jens Norskov (SLAC); Vitalij Pecharsky (Ames)

Analysis:

Mark Ruth (lead, NREL); Amgad Elgowainy (co-lead, ANL); Josh Eichman (NREL); Joe Cordaro (SRNL); Salvador Aceves (LLNL); Max Wei (LBNL); Karen Studarus (PNNL); Todd West (SNL); Steve Wach (SRNL); Richard Boardman (INL); David Tamburello (SRNL); Suzanne Singer (LLNL)

Why national labs along with industry?



Why National Labs Along with Industry?

- **NLs:** Unique skills/capabilities, ideally suited for addressing the challenges of tomorrow's energy system. H2@Scale vision only possible through the NL efforts.
- **Gov't:** No profit in developing this system in today's market, but needs to be ready for future energy systems needs. Consideration of societal impacts/costs. Both global and local. Can enable or derail potentially.
- **Commercial/industrial engagement critical:** Focus on enabling the vision of the long-term, through the short-term and mid-term steps.

What does success look like?



What Does Success Look Like?

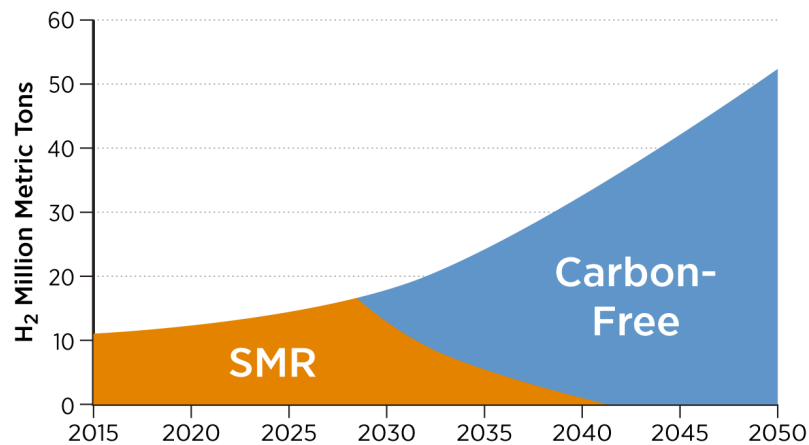
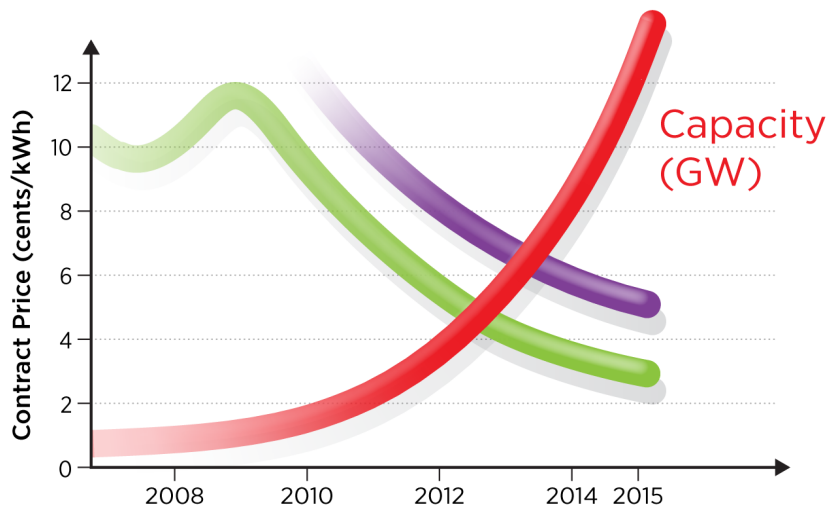

Going from
10 million
MT of H₂
from SMR to

50

million MT
from carbon-
free sources,
will enable a

50

% decrease
in CO₂
emissions
by 20

50

H₂ @ Scale



Reduction by Sector

75%
Grid

25%
Transportation

25%
Industrial

MORE

**Jobs
Security
Resiliency**

Creating a sustainable future

50% fewer GHG emissions **2050**
than today . . . by

Additional Content/Backup Slides

H₂@Scale components

H₂@Scale history/timeline

H₂@Scale connection to energy storage

H₂@Scale safety perceptions/concerns

H₂@Scale connection to grid

Cross-DOE-office connections

QTR connections

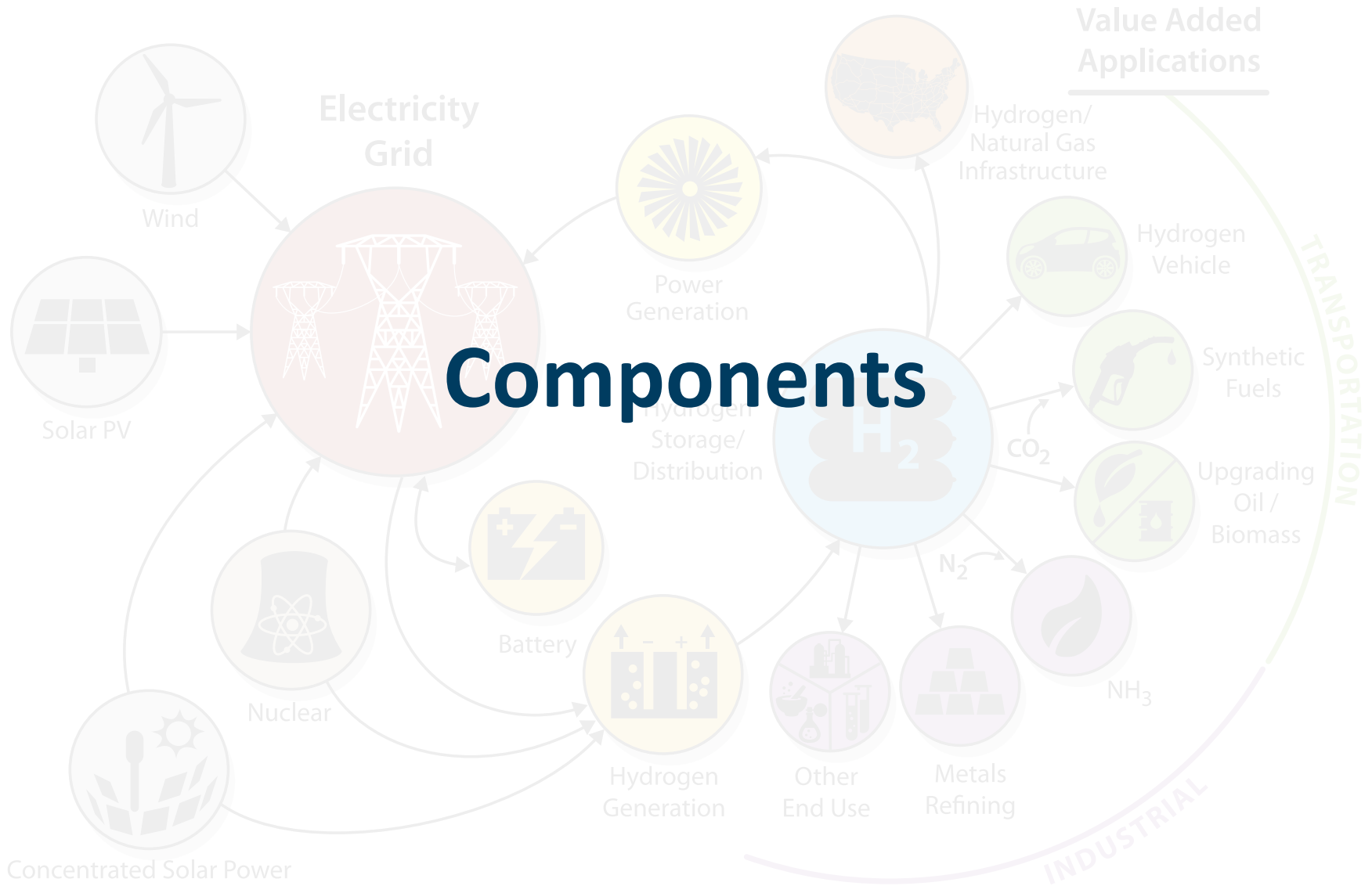

Conceptual H₂ at Scale Energy System*

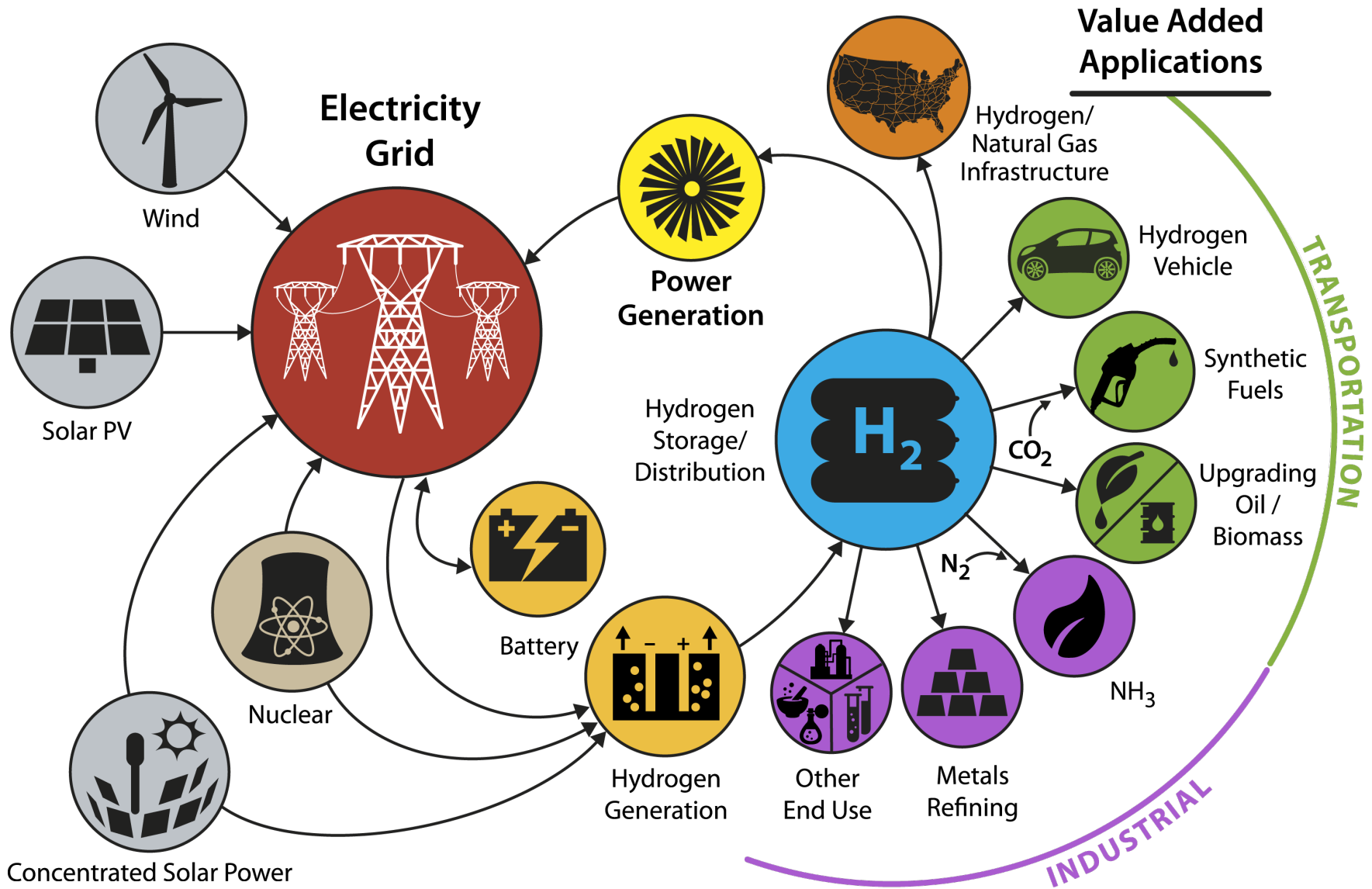

*Illustrative example, not comprehensive

Low- and High-T H₂ Generation

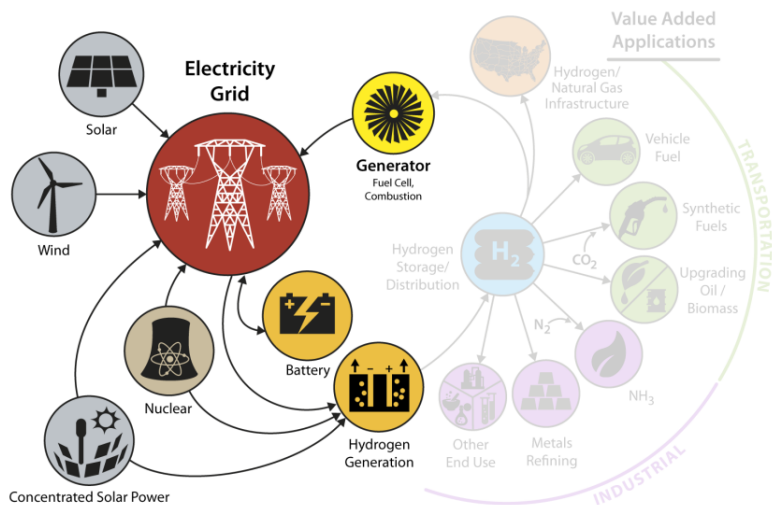

Cost Distribution
PEM System

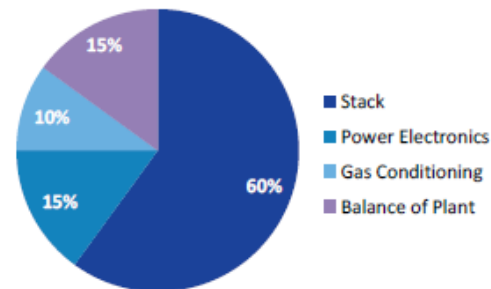

Specific H₂ Production Technology Needs

- PEM electrolysis
 - Cell/Stack Components
 - Power electronics/BOP
- Advanced alkaline electrolysis (membranes)
- Solid oxide electrolysis/thermal chemical
 - Oxide conducting materials
 - Thermal integration

DOE Programs Impact: EERE (FCTO, Solar, Wind, AMO); OE/Grid; NE; FE; SC

H₂ Storage and Distribution

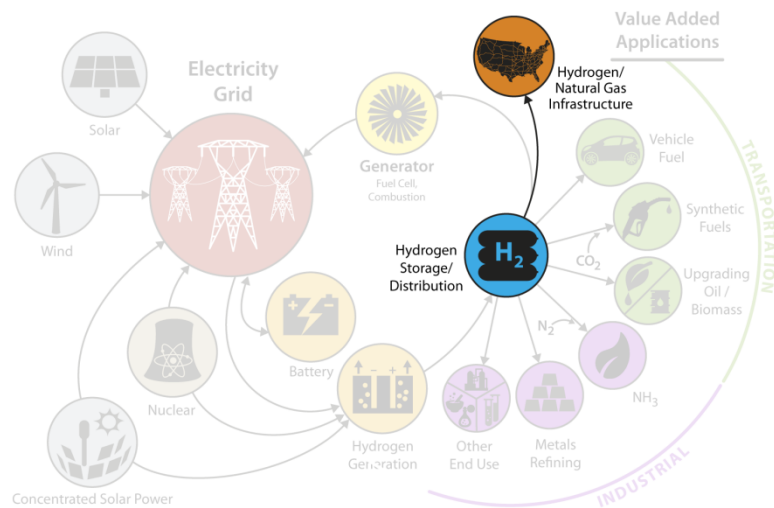

Specific Technology Needs

- Hydrogen Storage
 - Chemical/metal hydrides
 - Materials systems
 - Catalysis
- Physical Storage
 - Geologic
 - Manufactured
- Direct Electro-Chemical Hydride Conversion
- Distribution
 - Compression
 - Liquefaction
 - Materials Compatibility (*Hydrogen Embrittlement*)
 - Leak Detection/Repair
 - Hydrogen Contamination/Purification
 - Materials Compatibility
 - Grid Integration/Optimization

Research Priorities

- Development of storage/delivery systems for large-scale grid and industrial use
- Assessment of potential for integration with existing technology and infrastructure
- System analysis, integration and optimization

DOE Programs Impact: EERE (FCTO, AMO); OE, FE; SC

H₂ Utilization

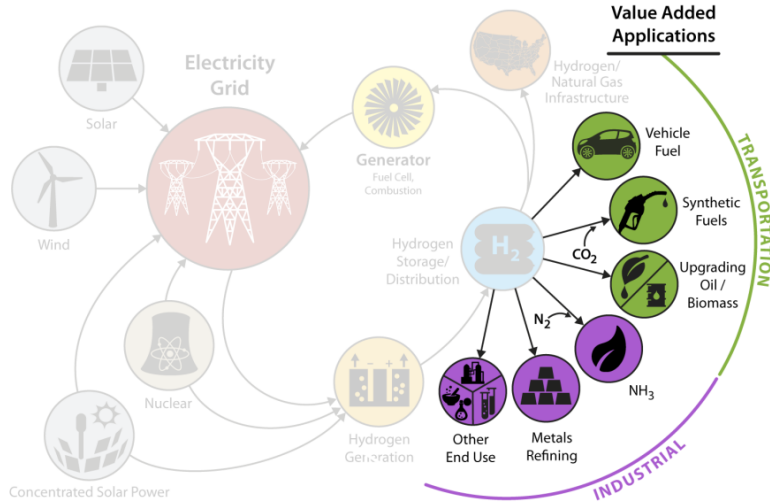

Specific H₂ Utilization Technology Needs

- Ammonia production
 - Distributed/modular
- Refineries and Biofuels
 - Process integration
- Metals and glass making
 - Game changing direct reduction
 - Reducing gases for annealing/
– tempering
- Combustion Processes
 - Burner design and testing
 - Flame chemistry impacts
 - Use of oxygen
- H₂ Heat Pumps
 - Waste heat recovery
 - Heat amplification / cooling

Research Priorities

- New process chemistry with H₂ used as a reductant
 - Chemical, Fuels, Metals Production
- Process efficiency improvement
 - Industry and power systems
- Process heat integration with intermittent H₂ generation
- H₂ / H₂-rich flame modeling

DOE Programs Impact: EERE (AMO, FCTO, Wind/Solar); NE; FE; ARPA-E; SC

Foundational Science

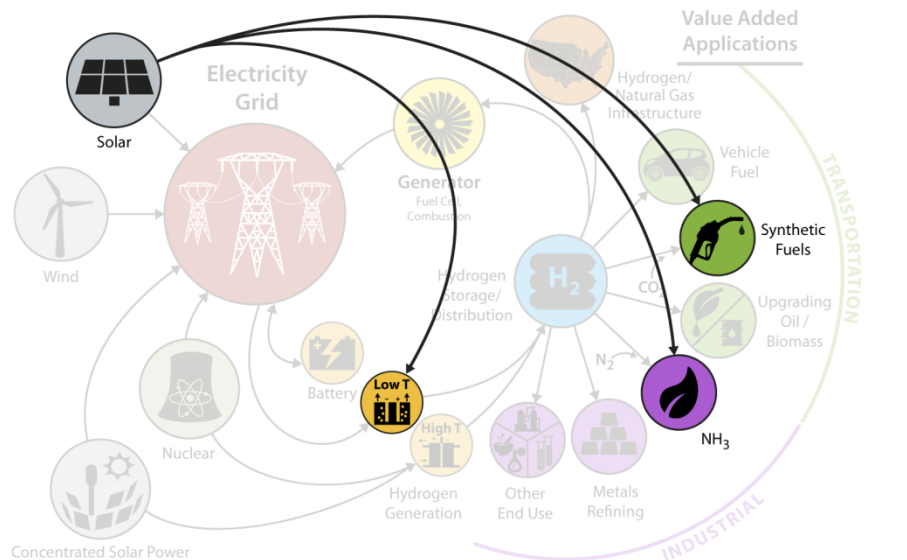

Fundamental understanding of potentially revolutionary technologies for other chemical bond energy storage/conversion.

Numerous chemistry/ materials issues: Catalysis/Reactions

*Systems far from equilibrium
Confined catalysis*

Corrosion

Detection and understanding of rare events

Material interactions (Embrittlement)

User facilities

SNS, light sources, nanocenters, microscopy

ACSR and advanced computing

Big data

Algorithms for prediction multiscale physics

JCAP leveraged science

MGI (expansion)

dissolution, kinetics, solvents

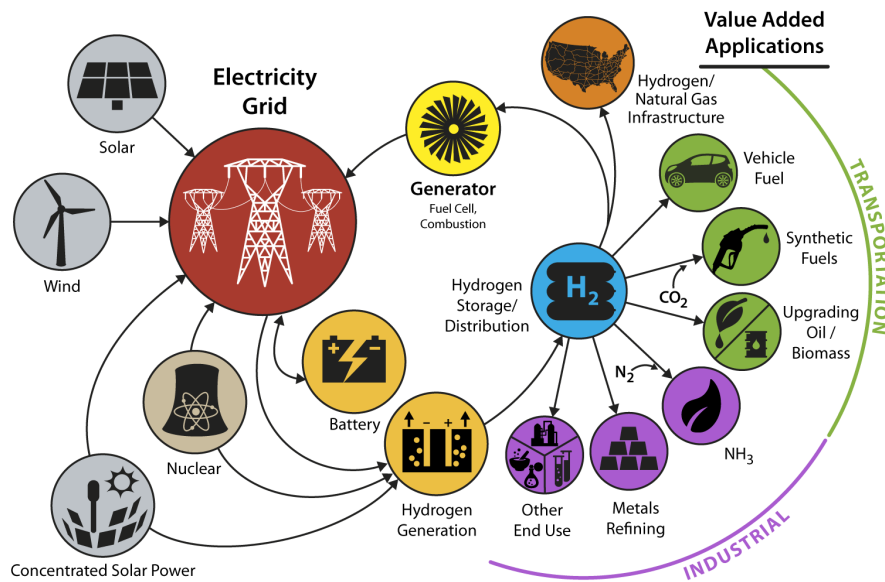

Grid Integration

Specific Grid Integration Technology Needs

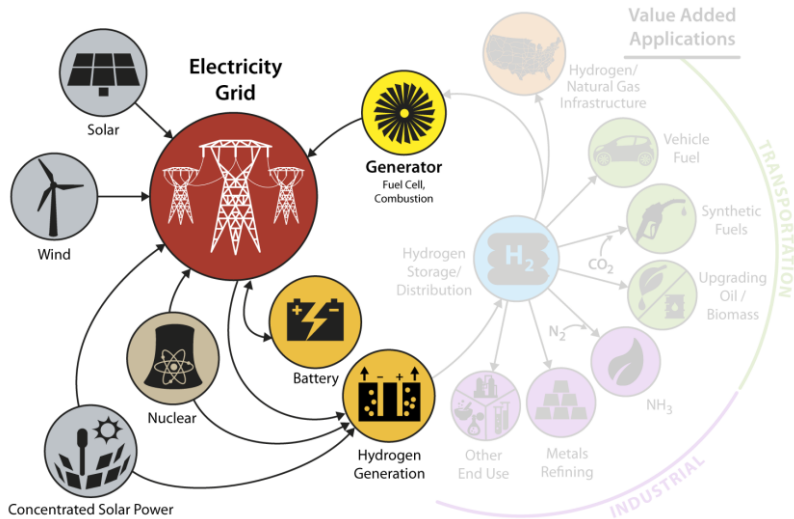

Research & Development Priorities

- Systems analysis
- Systems engineering
- Systems design and demo

- Affordability
 - Modest capital investment for production and storage
 - Renewable hydrogen source for marketplace revenue
- Flexibility- Scalable, deployable, multiple renewable hydrogen markets
- Reliability
 - Stable, sufficient power source
 - Inherently integrated element of grid
- Resilience- Distributed production and storage systems—large storage options
- Sustainability- Enable stable grid with abundant renewables-demand/response
- Security- Enable domestic, renewable energy resource

Analysis

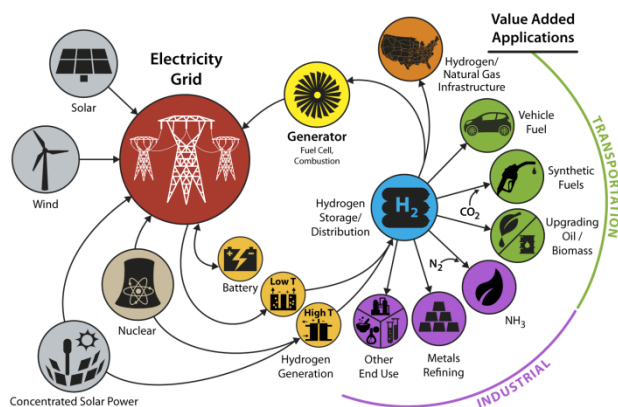

Analysis Priorities

- Specifying the role of hydrogen in deep decarbonization of the U.S. energy sector
- Understanding of drivers impacting energy sector evolution
- Quantification of hydrogen potential to meet seasonal electricity storage requirements
- Technoeconomic analysis
- Life cycle analysis

Specific Analysis Needs

- Role of hydrogen within energy sector
 - Energy sector evolution / capacity expansion analysis to identify key opportunities for hydrogen to support power, gas, industrial, and transportation sectors
 - Grid operations co-optimization with hydrogen providing grid support on short and long time-frames and on regional and national scales
 - Analysis of the hydrogen's benefits resilience, reliability, and robustness
- Technoeconomic analysis to support R&D direction in hydrogen generation, storage & distribution, and end use
- Life cycle analysis to identify opportunities to reduce GHG and criteria pollutant emissions

History/Timeline

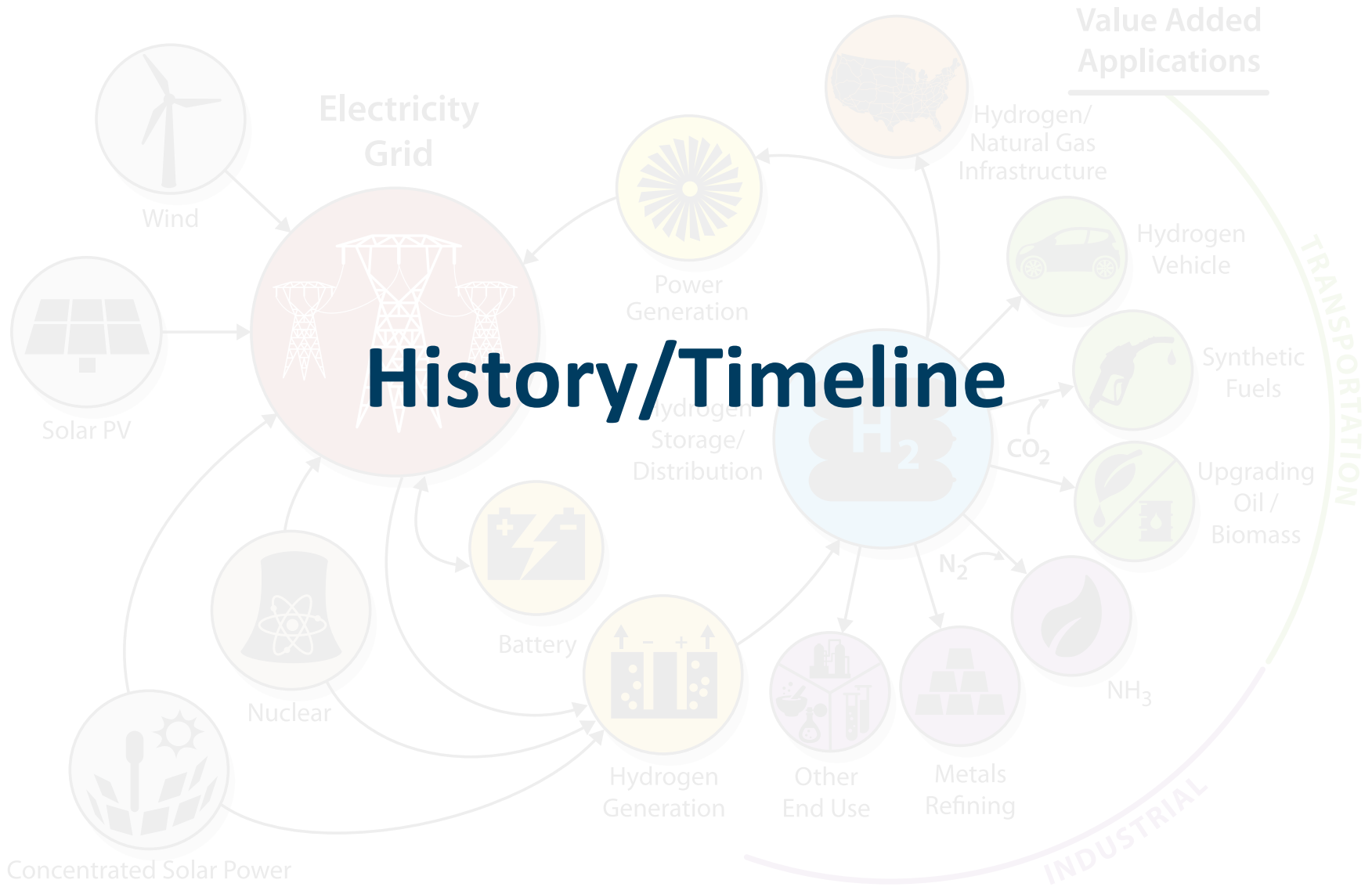

H₂ Big Idea Timeline

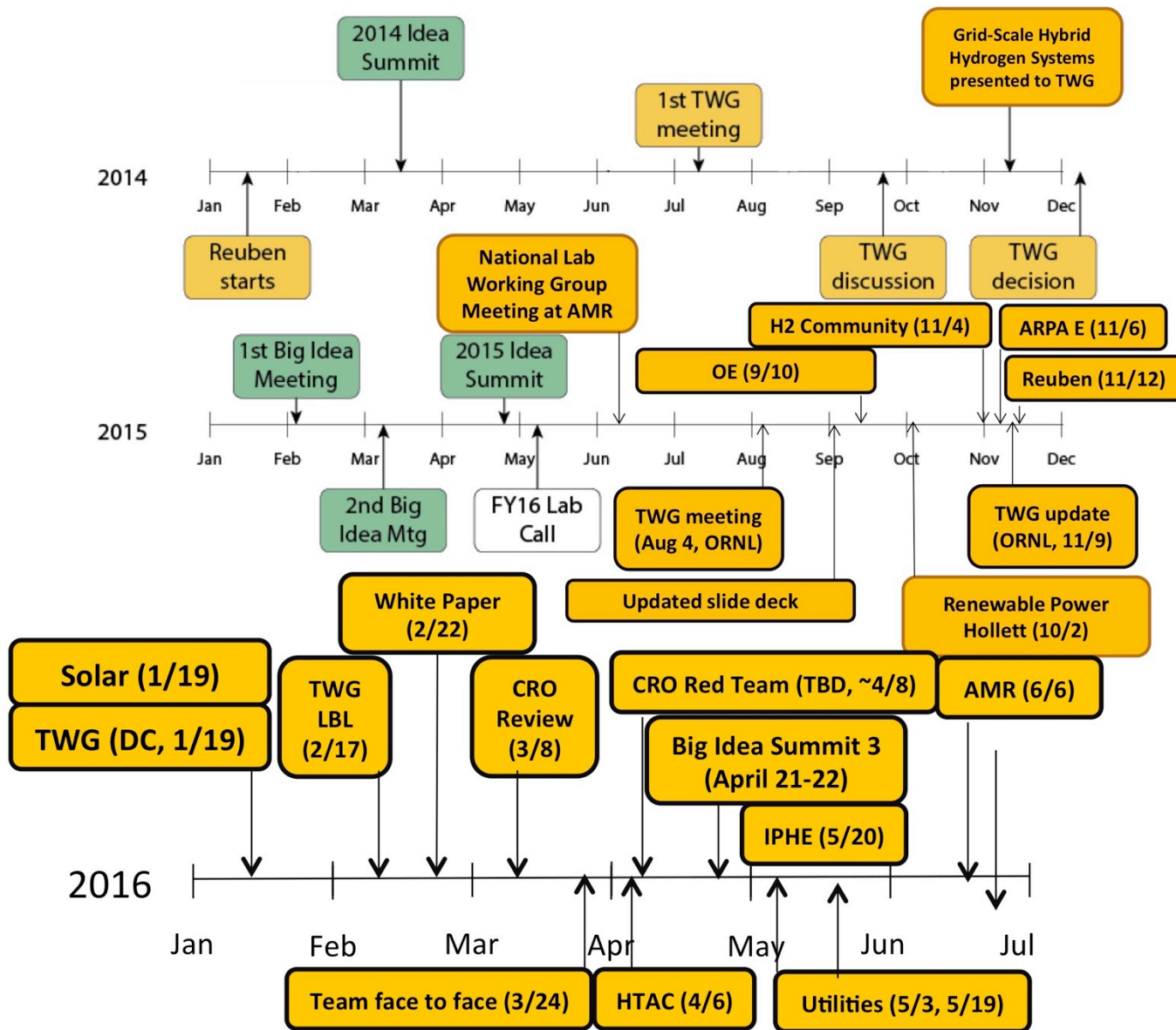

Connection to Energy Storage

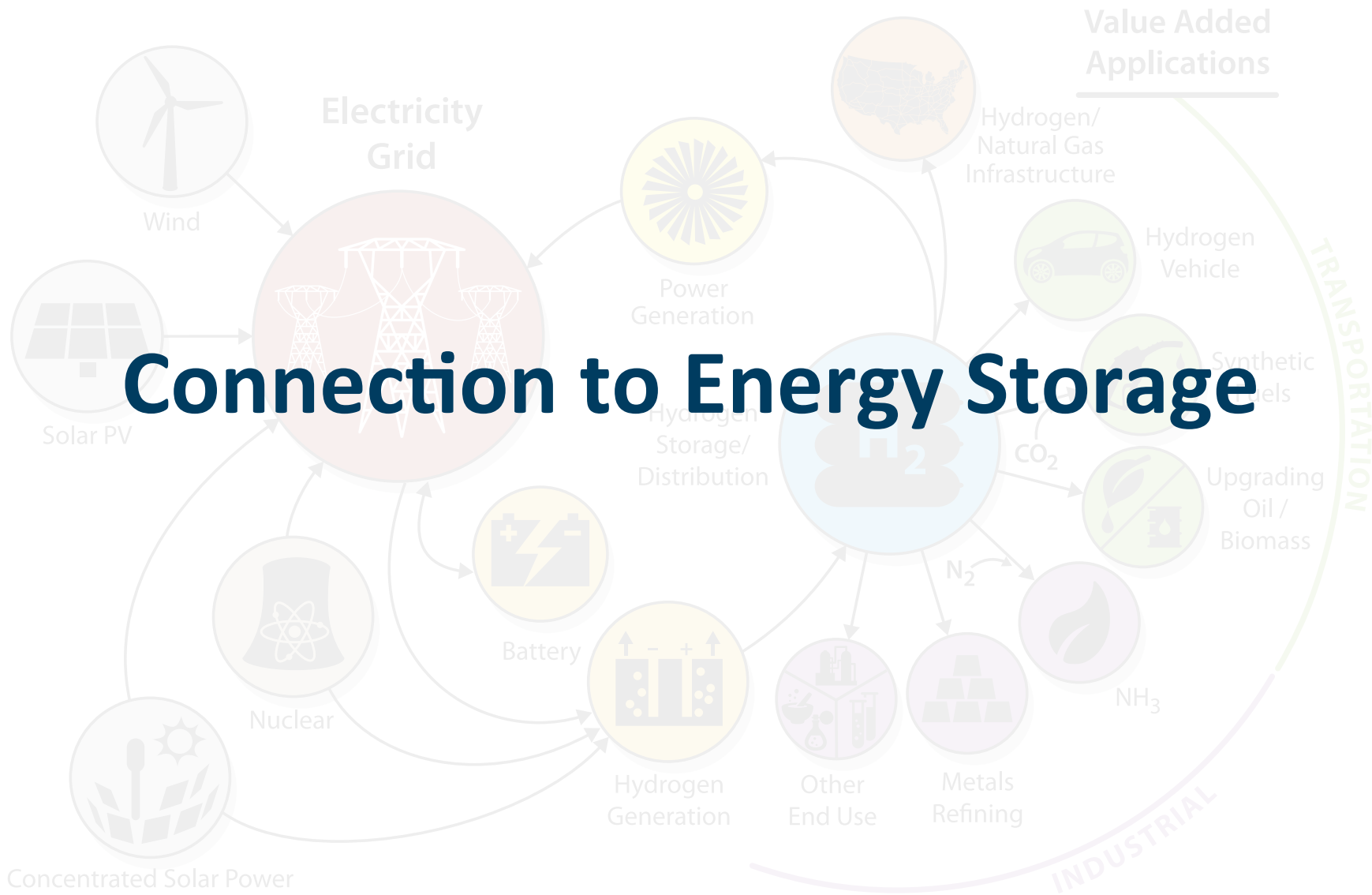

Storage Needs with Increased RE Penetration

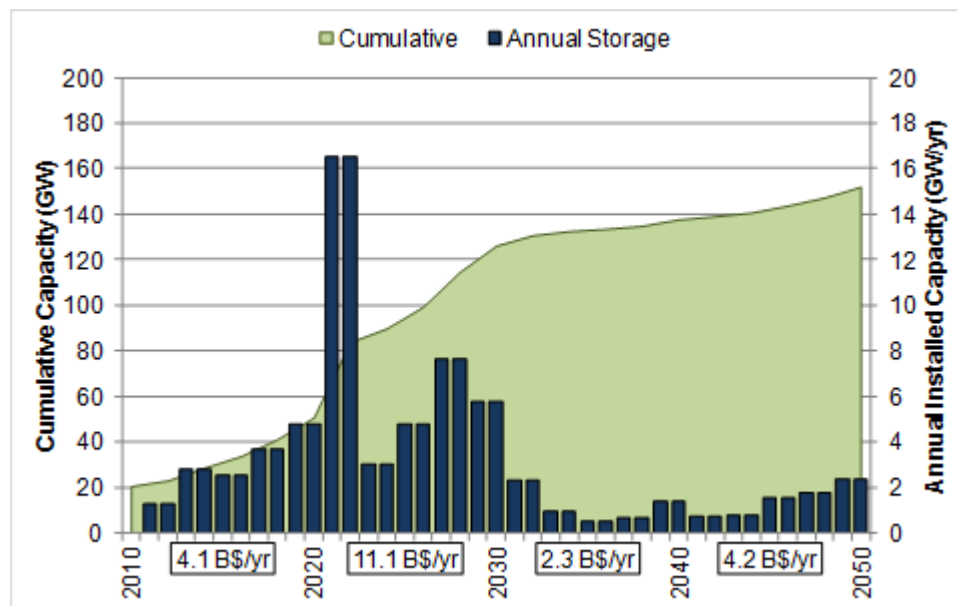
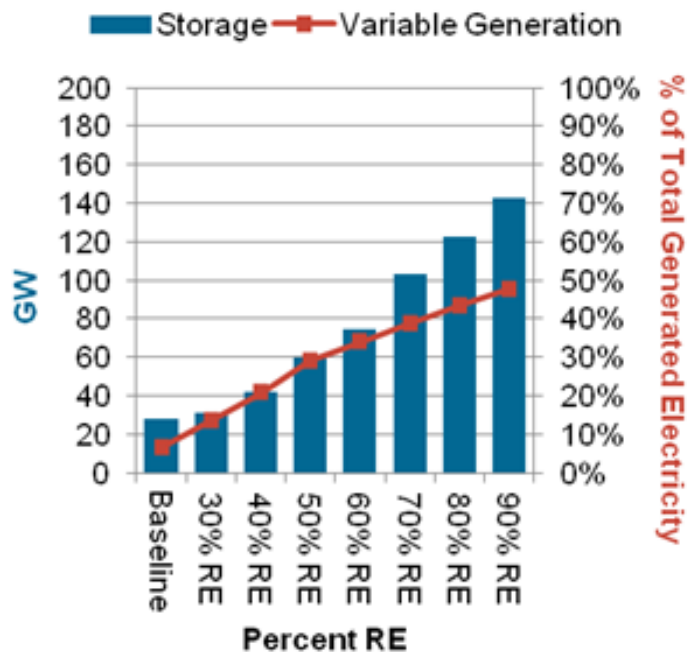

RE Futures Study

Comparison between Energy Storage Options

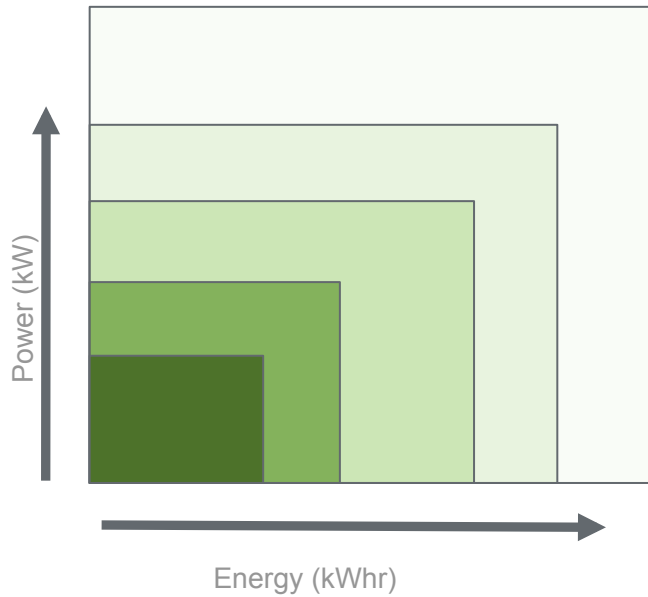

Battery systems

Power and Energy scale together

More energy storage = more batteries

Marginal cost of storage capacity is \$1400/kWh



Hydrogen systems

Power and energy scale separately

More energy storage = more tanks only \$140/kWh

10X

Source: Hydrogenics

Competitive Analysis vs. Battery Storage

Hydrogen vs. LiOH Battery Solution

Attributes	Pilot Project – Hydrogen Energy System	Pilot Project – Battery System	Full-Scale Project – Hydrogen Energy System	Full-Scale Project – Battery System
Favorable Total Cost of Ownership	▲	▲	●	✘
Technical Scalability	●	●	●	▲
Modularity	●	●	●	▲
Maintenance Requiements	●	●	●	●
Capital System Cost	▲	▲	●	✘
Environmental Attributes/Disposal	●	▲	●	✘
Conditioned Footprint	●	●	●	✘
Reliability	●	●	●	●
Expected Lifetime of Electrochemical Core	●	▲	●	✘

Good = ●; Concern = ▲; Not Good = ✘

Factor	Battery System	Difference	Hydrogen System
Net Energy Cost	\$1.69	2.5X +	\$0.68
Incremental Storage Cost	\$1400 - \$850/kWh	10x +	\$50-140/kWh
% of Time Full	71%	1.6x +	43%
Wind Energy Wasted (1)	7.9/12.3 (64%)	2.6x +	2.8/10.9 (25%)
Capital Cost	69M\$	2.5x +	28M
Total Life Cycle Cost	91M\$	2.6x +	36.5M\$
Net System Efficiency	35%	8% +	39%
Environmental Impact	D	+	O

Source: Hydrogenics

Many Jobs, Many Solutions

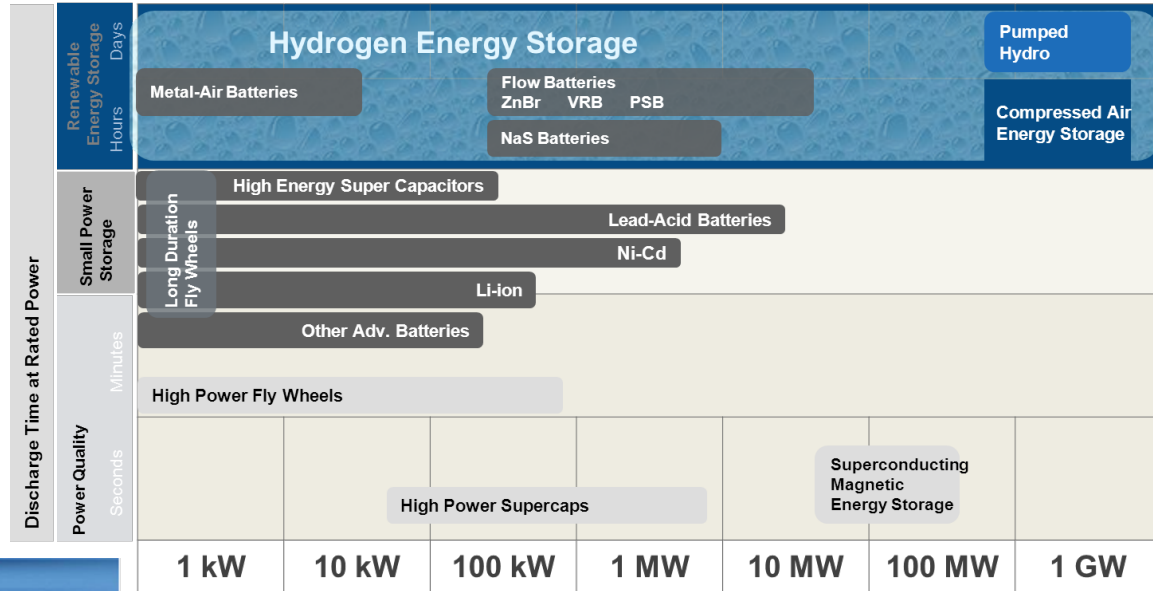

Source: Electricity Storage Association

Capacity, Not Efficiency a Larger Driver for Renewable Storage

Source: Hydrogenics

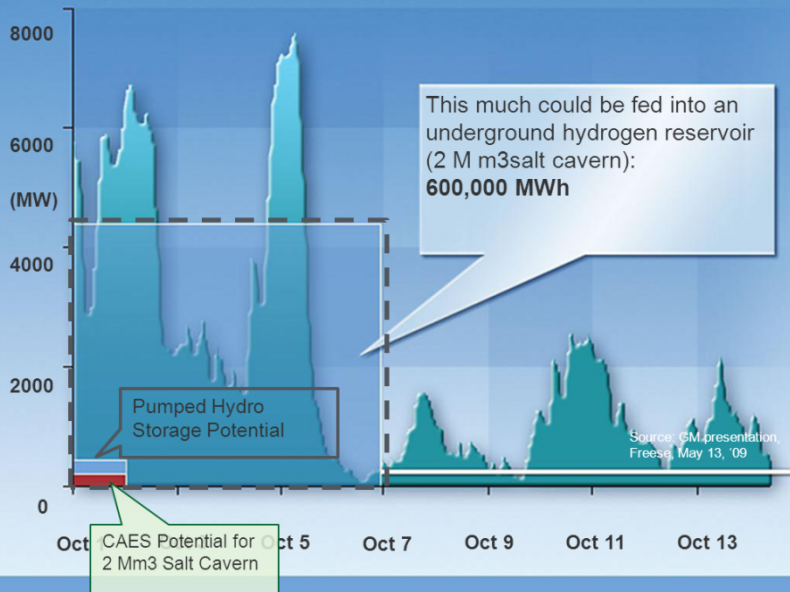

Only hydrogen offers storage capacity for several days or weeks

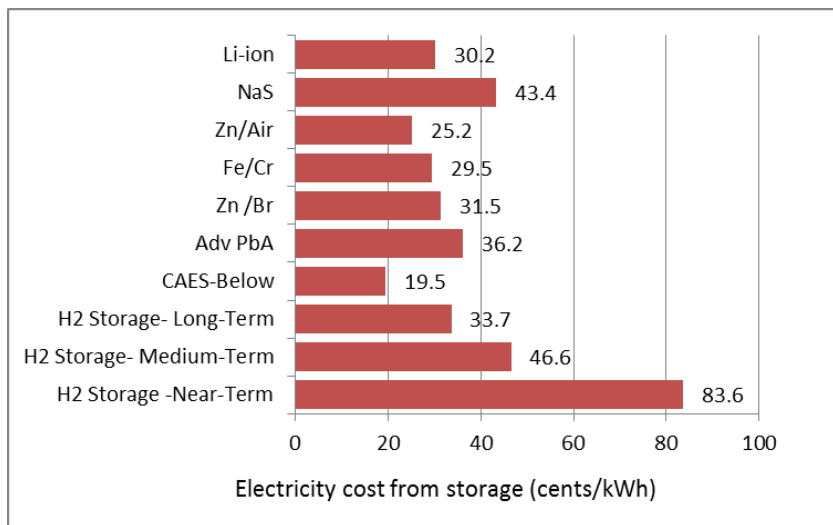

Only Long-Term H₂ Storage competes in single day cycling

But multi-day energy storage will likely be necessary in a high renewables penetration scenario, if there is more value placed on otherwise curtailed renewable resources due to:

- Higher Renewable Portfolio Standards
- Carbon Dioxide Emission Controls

Figure 1. Price of on-Peak electricity for various below-ground H₂ & CAES storage and battery storage options with one-day storage and 10% "free" (stranded) energy for a 10MW output over 4 hours (40MWh/day) & NG = \$5/MBTU (for CAES) [All battery & CAES costs are based on the lower EPRI estimates.]

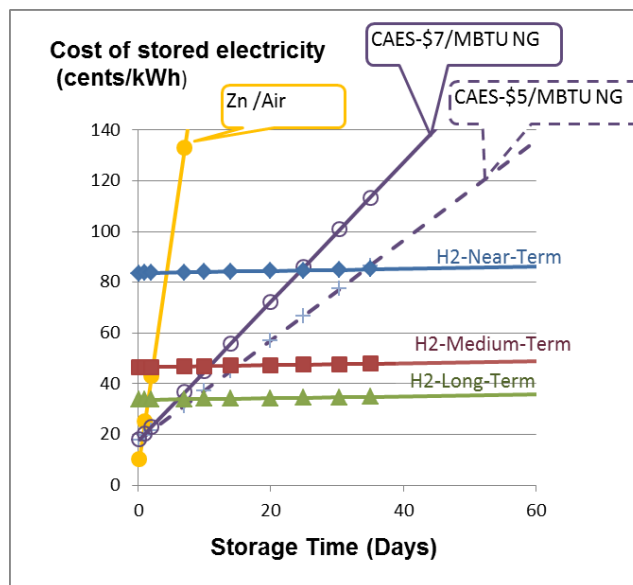
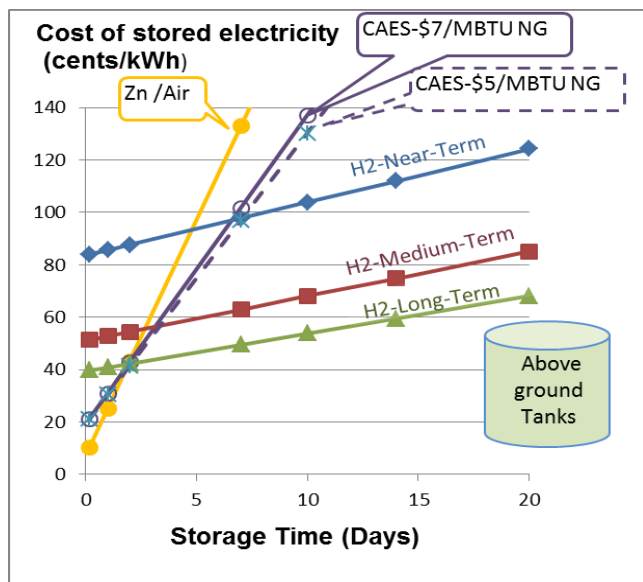

Need to understand when there is economic value for longer storage times under high penetration renewables scenarios

Source: Sandy Thomas

Energy “Storage”

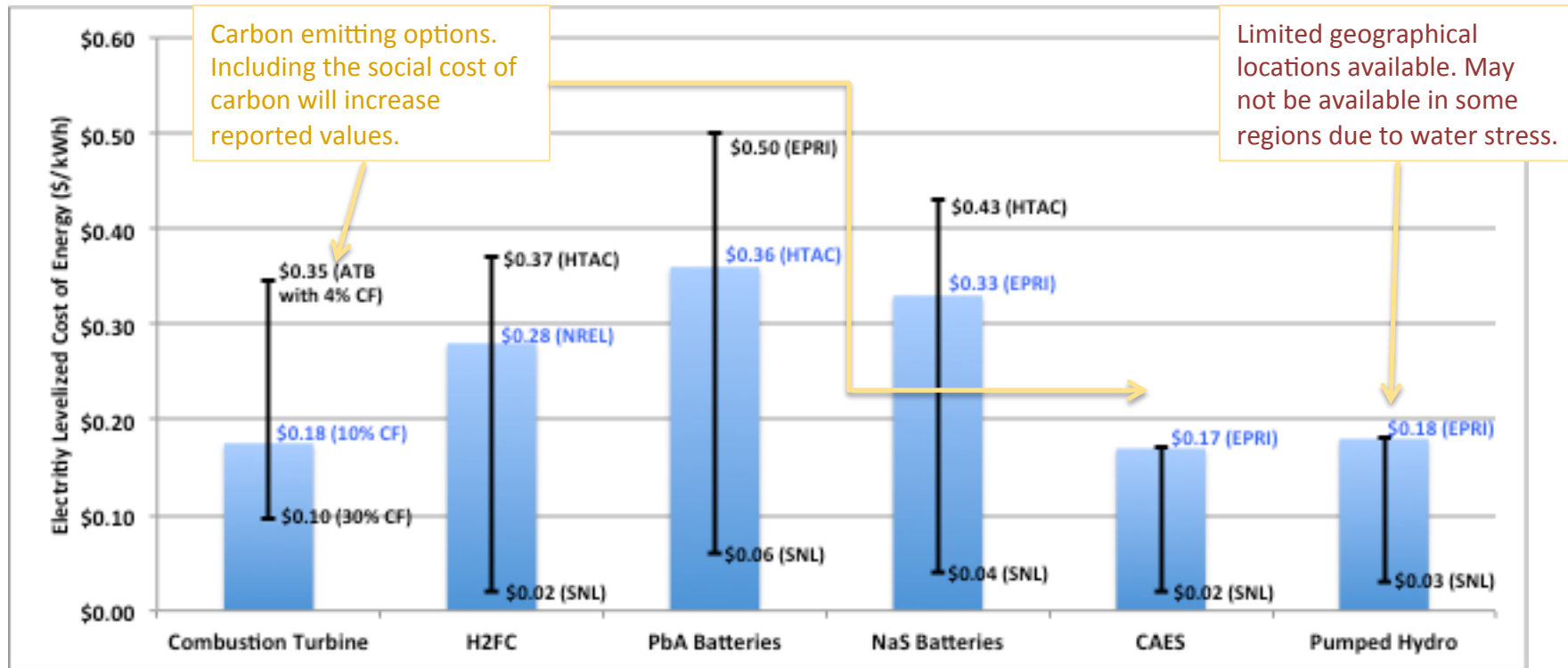

Storage will need to compete with flexible generation on economics and probably emissions. Efficiency challenges exist, but when considering renewable electrons, it is economics, not efficiency, that is the critical metric.

Hydrogen goes beyond other technologies by providing a sink for grid electrons rather than a just a capacitor.

Non-energy values (e.g., ancillary services, capacity) are not included in these analyses but are likely to benefit storage as compared to combustion turbines (see Denholm, et al “The Relative Economic Merits of Storage and Combustion Turbines for Meeting Peak Capacity Requirements under Increased Penetrations of Solar Photovoltaics” (2015).

ATB: Annual Technology Baseline; CF: Capacity Factor; H2FC: Hydrogen Fuel Cell; CAES: Compressed Air Energy Storage

Safety Perceptions/Concerns

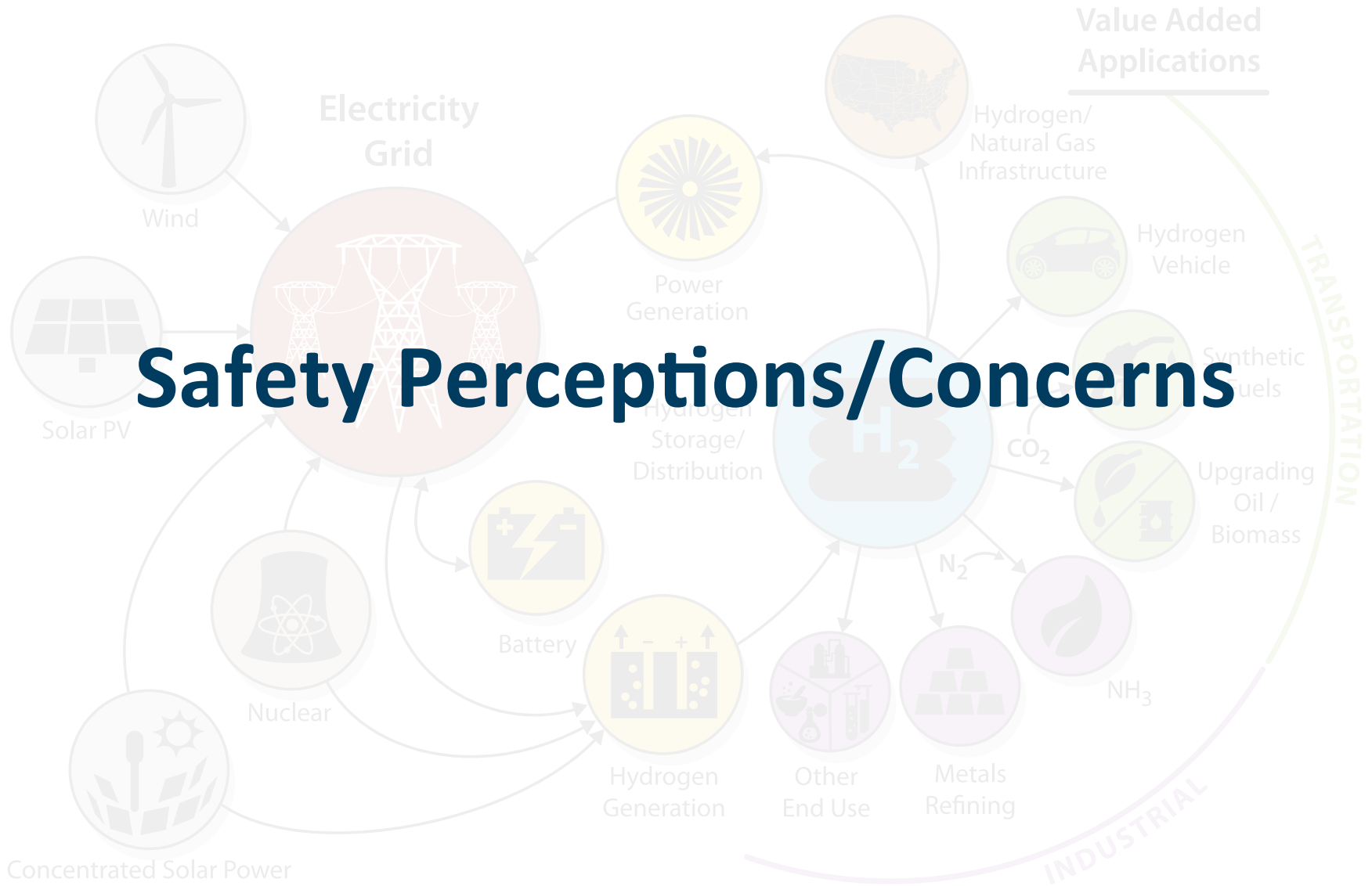

Hydrogen Safety

What is the first thing you think of when “Hydrogen Safety” is mentioned?

The flames observed are actually the burning aluminum powder, and lacquer applied to the canvas skin to mitigate against lightning strikes, not the hydrogen inside the airship. ¹

¹ *The Freedom Element, Living with Hydrogen*, Dr. A. Bain, Blue Note Publications, Cocoa Beach, FL, USA, 2004.



Hindenburg Disaster: May 6, 1937
Lakehurst, NJ

Fuel Flamability Comparison

	Hydrogen	Gasoline Vapors	Natural Gas
Flammability Limits (in air)	4-74%	1.4-7.6%	5.3-15%
Explosion Limits (in air)	18.3-59.0%	1.1-3.3%	5.7-14.0%
Ignition Energy (MJ)	0.02	0.2	0.29
Flame Temp. in air (°C)	2045	2197	1875
Stoichiometric Mixture (most easily ignited)	29%	2%	9%

“Hydrogen safety concerns are not cause for alarm; they simply are different than those we are accustomed to with gasoline or natural gas.”
AirProducts and Chemicals, Inc.

Fuel Leak Simulation
Punctured tank and ignition
with equivalent energy release

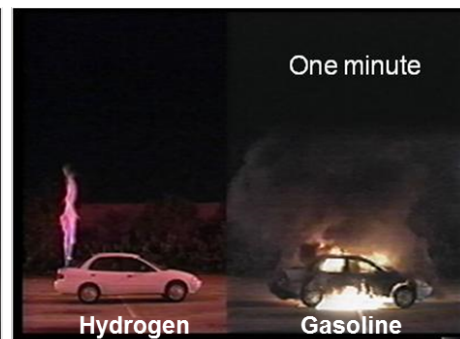
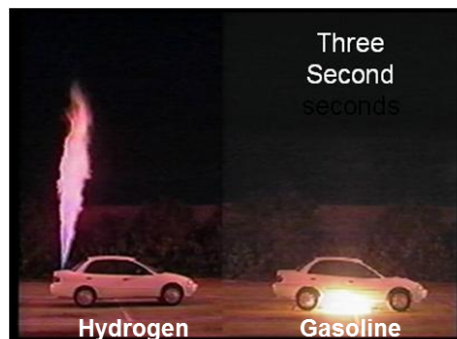

H₂ Safety

Hydrogen Risk Assessment Models (HyRAM)

Developed a tool to enable integrated probabilistic and deterministic modeling (Quantitative Risk Assessment) for end users.



LH2 Reduced Separation Distances

Use of performance-based design to reduce separation distance and overall station footprint. Published report on ongoing research and research gaps in liquid hydrogen models (<http://prod.sandia.gov/techlib/access-control.cgi/2014/1418776.pdf>)

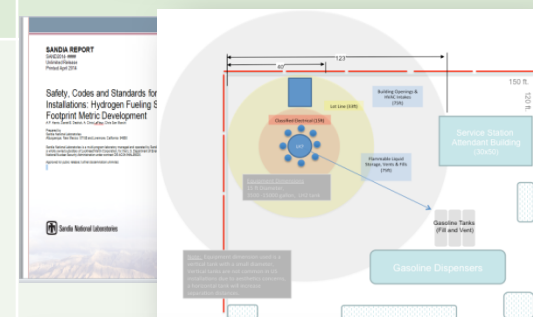

Materials Compatibility

Testing of hydrogen compatibility of materials. Use of austenitic stainless steel provides life-time cost reductions (High fatigue stress can be achieved with cycles to failure >10,000 cycles). Development of high-pressure hydrogen materials testing protocol. (www.sandia.gov/matlsTechRef/)

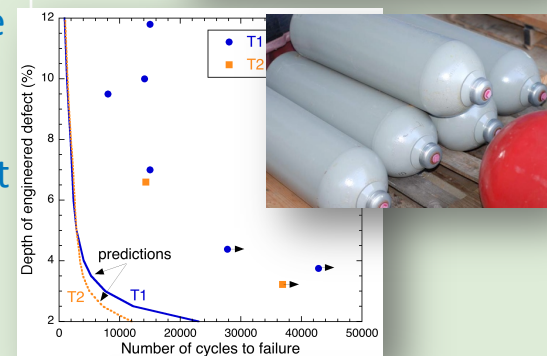

Fuel Quality

- Developing a concept inline hydrogen analyzer to continuously monitor impurities and alert the user to any fuel quality issues at the station.
- Investigating effect of performance at low Pt (toward DOE target) loadings.

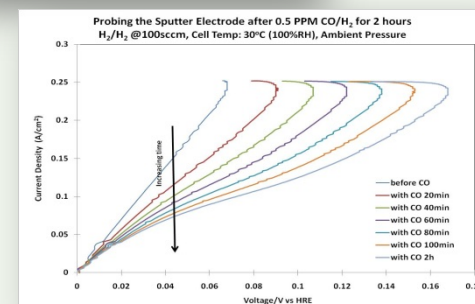

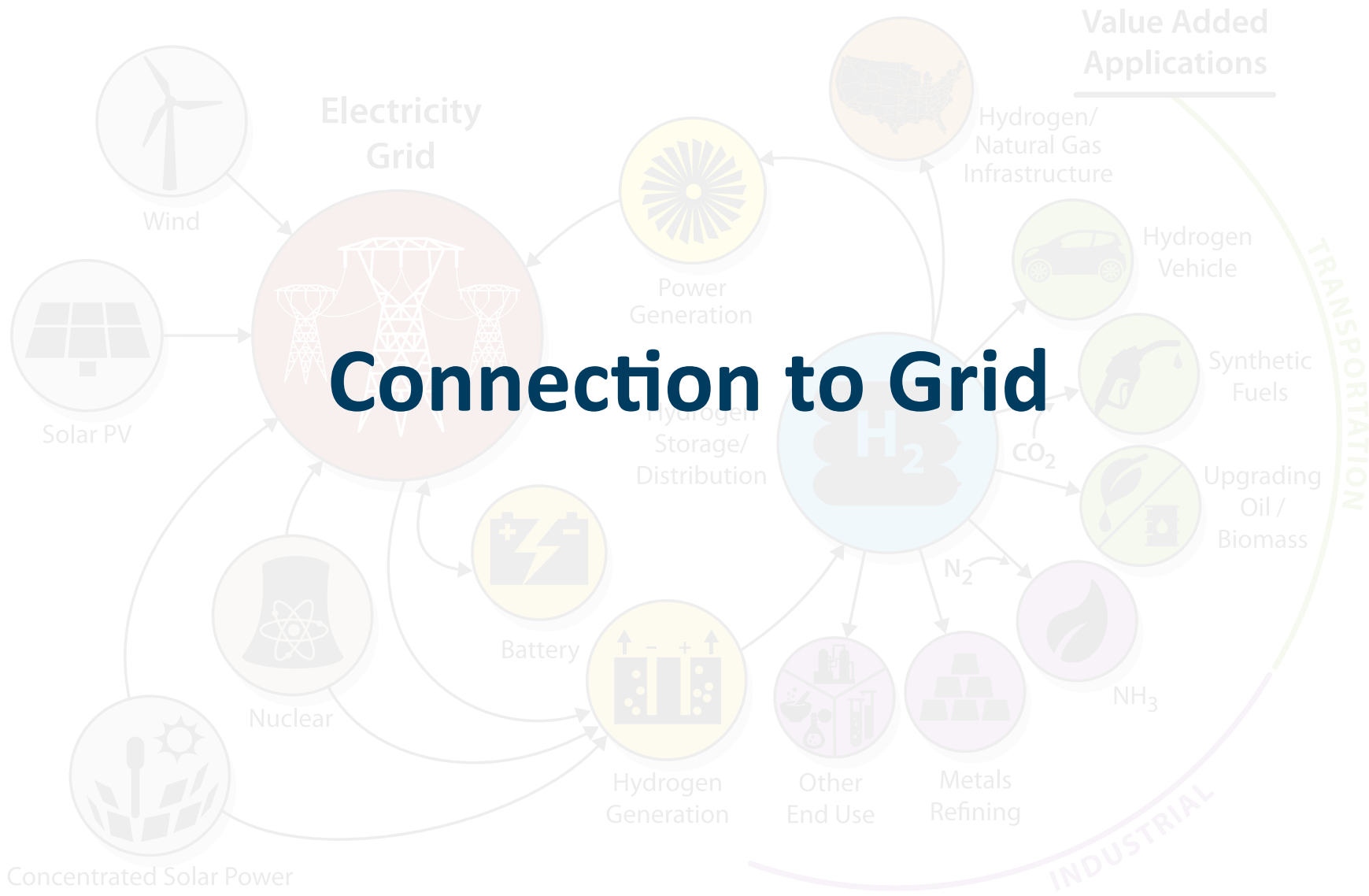

Future Electric Grid

Specific Grid Integration Technology Needs

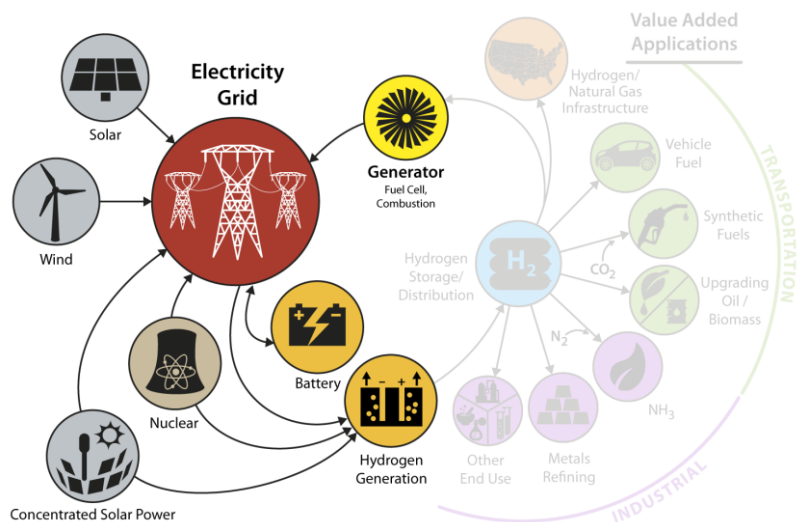

Research & Development Priorities

- Systems analysis
- Systems engineering
- Systems design and demo

- Affordability
 - Modest capital investment for production and storage
 - Renewable hydrogen source for marketplace revenue
- Flexibility- Scalable, deployable, multiple renewable hydrogen markets
- Reliability
 - Stable, sufficient power source
 - Inherently integrated element of grid
- Resilience- Distributed production and storage systems—large storage options
- Sustainability- Enable stable grid with abundant renewables-demand/response
- Security- Enable domestic, renewable energy resource

Grid Support

- **How does H₂ impact Reliability, Resiliency, Security?**
 - We're not sure and need your help, but there are specific features that are likely to have impact, there is also the ability to control (improve) impacts
- **Ancillary services (including fast dynamic response)**
- **Large scale potential**
 - Scalability
 - Flexibility (sighting and integration)
 - Energy storage

Resiliency

- Blackouts cost economy \$billions annually.
- H₂ can provide resiliency (how is H₂ impact quantified, validated, and/or monetized?)

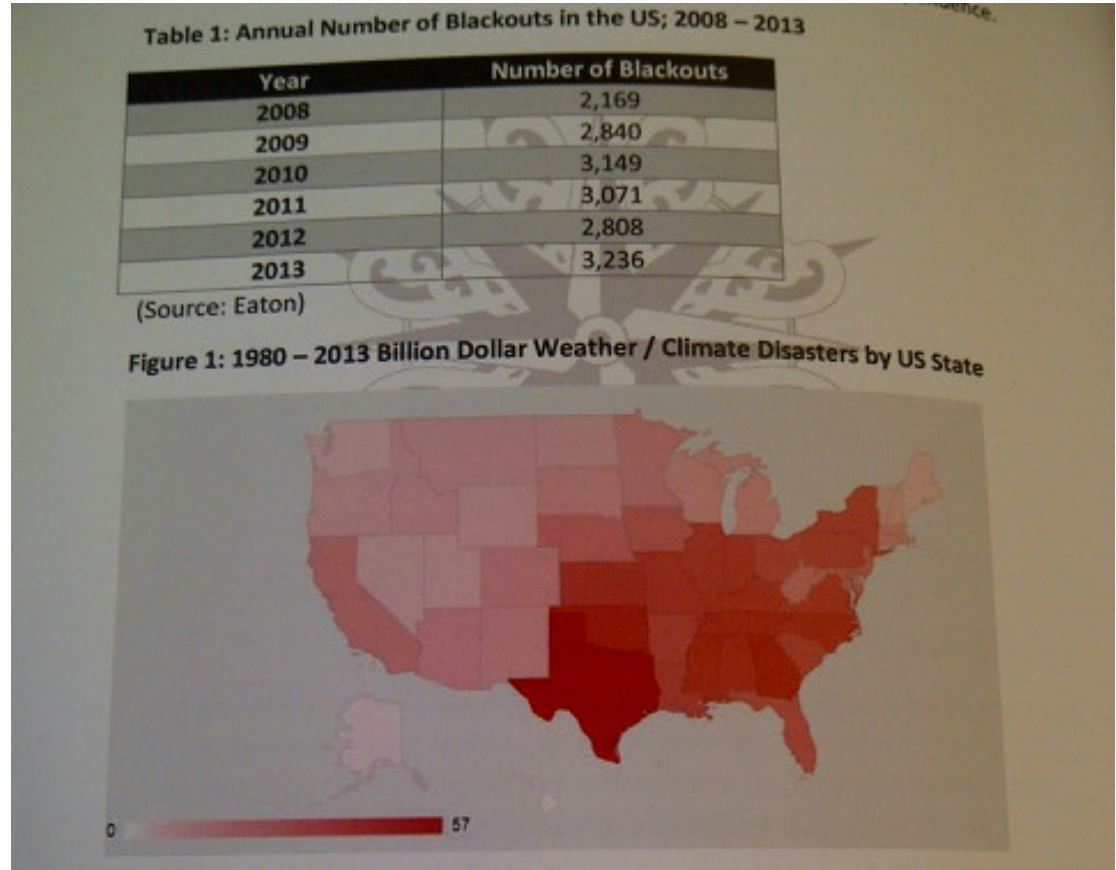

Grid Support

- Ancillary services (response time/duration)

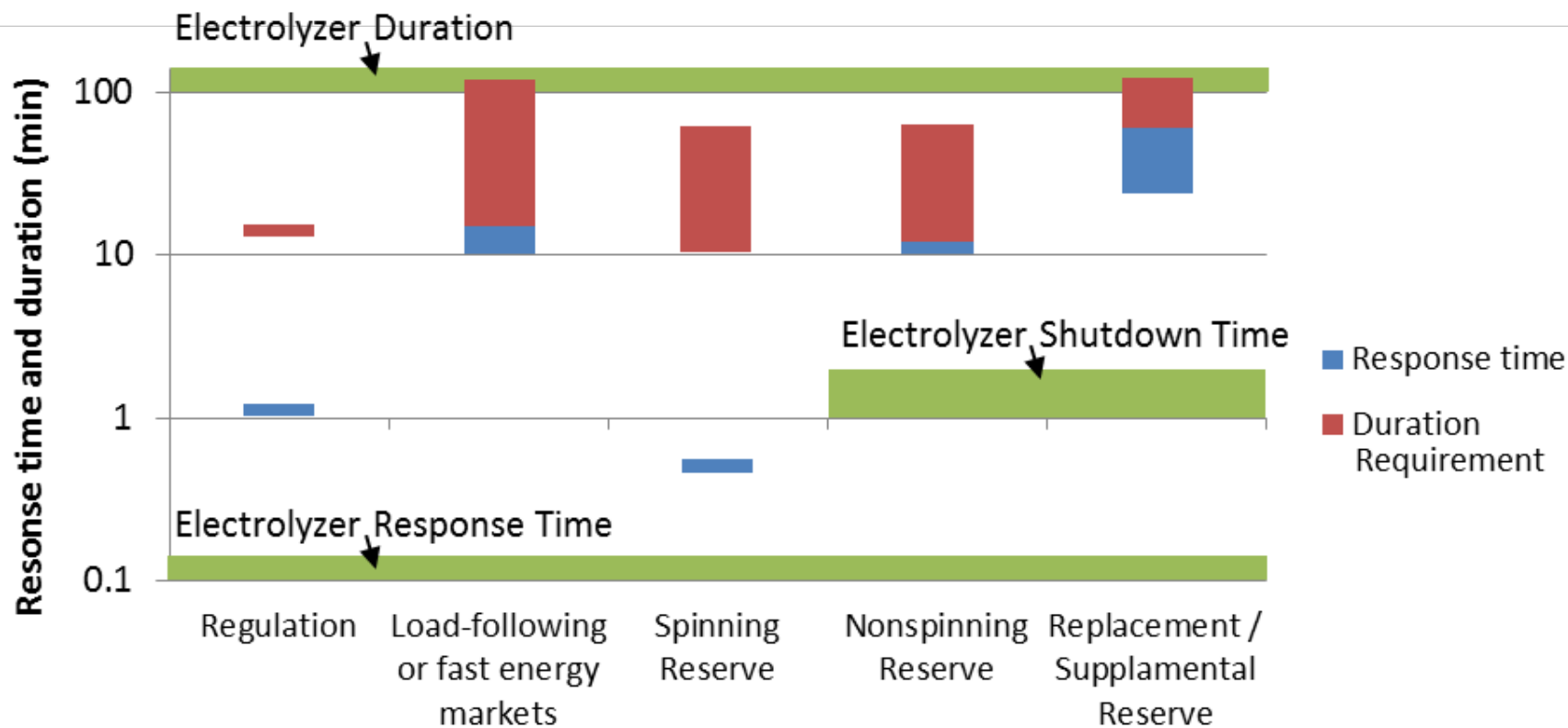

Exceptional Energy Storage Capability and Real Time Dynamic Response

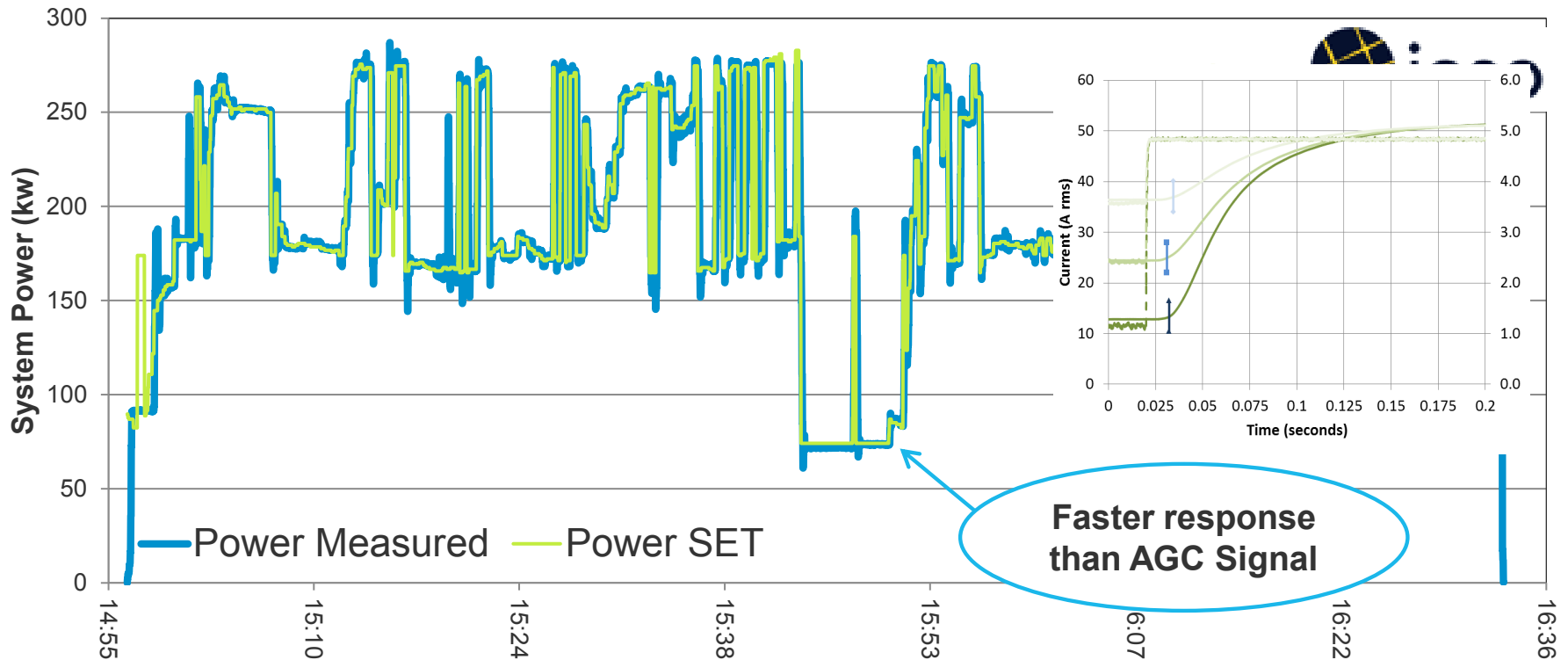

Note: IESO signal test completed June 2011 – AGC (Automatic Generation Control)

H₂ Storage Potential

- Current natural gas system
 - 305,000 miles of transmission pipelines
 - 400 underground natural gas storage facilities
 - 3.9 Bcf underground storage working gas capacity
- If transitioned to H₂ equates to...
 - 38 billion kg of H₂

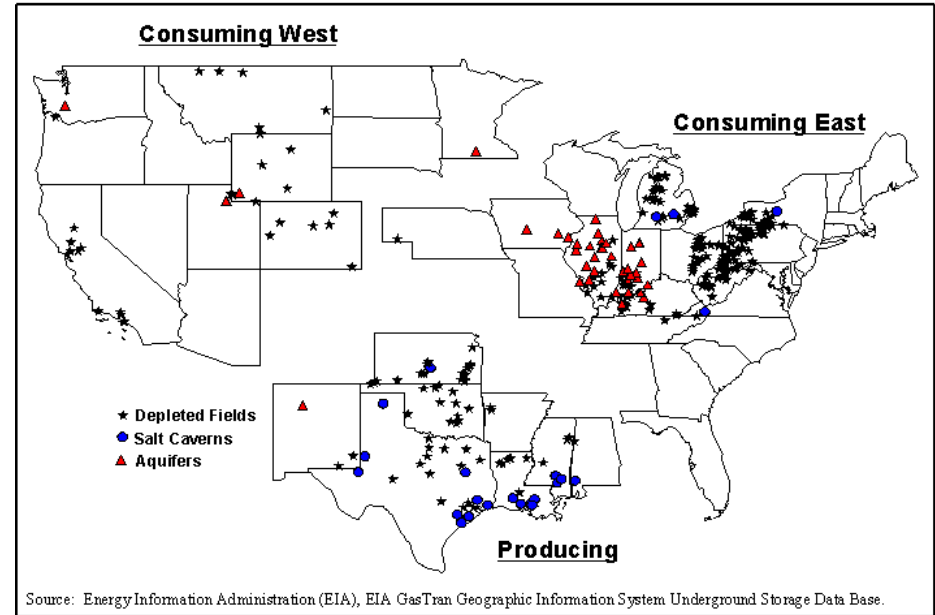

H₂ storage capacity
~2 months energy needs potentially available
Does this reflect resiliency or security?

Source: www.eia.gov/pub/oil_gas/natural_gas/analysis_publications/ngpipeline/index.html

Scalability/Flexibility

- Distributed options vs. centralized options
 - From sub-MW to GW scale
 - Coupling with local generation (wind, PV, CSP, NE)
 - Electricity transmission vs. hydrogen distribution
 - On-sight consumption or conversion

Cross-DOE-Office Connections



Cross-Office Collaborations

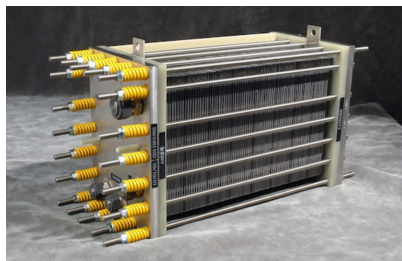
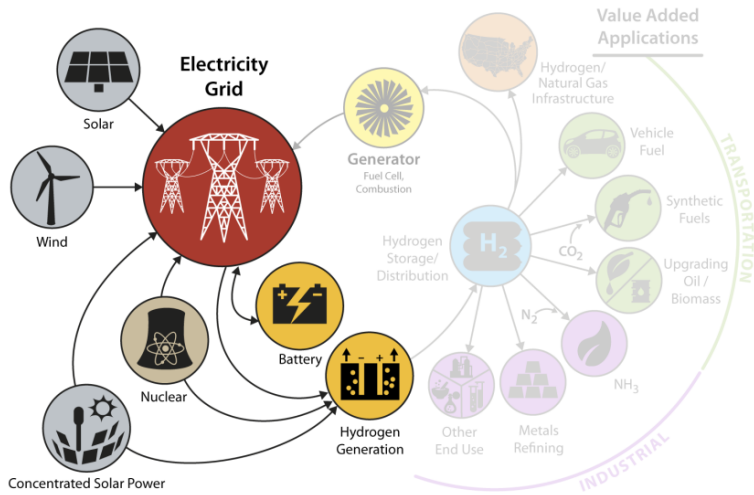

R&D Focus	Research Activities	DOE Programs	Impact
Low T H₂ Production 	<ul style="list-style-type: none"> Reduce precious metal loadings on electrolyzer electrodes Low-cost, durable high-conductivity membranes Low-cost, corrosion resistant, thin film protective coatings Develop durable systems for intermittent operation Develop transformational technologies for water splitting from renewable feedstock 	ARPA-E BES SETO Wind OE FCTO	<ul style="list-style-type: none"> ✓ Increase the value of renewable electrons ✓ Enable high penetration of renewables on the grid ✓ Improve efficiency and stability of electrochemical and photoelectrochemical technologies ✓ Decrease the cost of H₂ at high volume by 5X
High T H₂ Production 	<ul style="list-style-type: none"> Materials discovery and development for high T electrolyzers (e.g. SOEC) Component durability in intermittent heat sources Develop transformational high-temperature redox redox materials and reactor components for hydrogen generation 	NE BES SETO FCTO	<ul style="list-style-type: none"> ✓ Reduce electricity consumption of electrolysis by leveraging waste heat ✓ New materials discovery ✓ Improve thermochemical/concentrated solar system design and components including materials, heliostat, and power electronics
H₂ Storage and Distribution 	<ul style="list-style-type: none"> Polymer and steel compatibility with H₂ Advanced liquefaction and refrigeration Materials for harsh environments Reduce moving parts, and improve efficiency of pipeline and forecourt compressors Use of fiber reinforced composite polymers in pipelines 	NNSA BES ARPA-E AMO FE FCTO	<ul style="list-style-type: none"> ✓ Develop physics-based understanding of hydrogen embrittlement ✓ Improve hydrogen liquefaction efficiency by > 60% ✓ Improve reliability and efficiency of gas compression ✓ Lower cost of high-pressure pipelines ✓ Enable over 2X reduction in cost of hydrogen delivery and dispensing

Cross-Office Collaborations

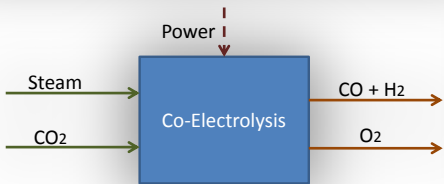
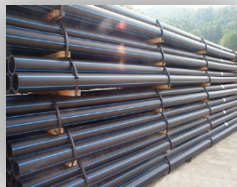
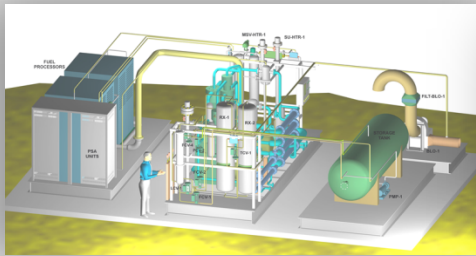
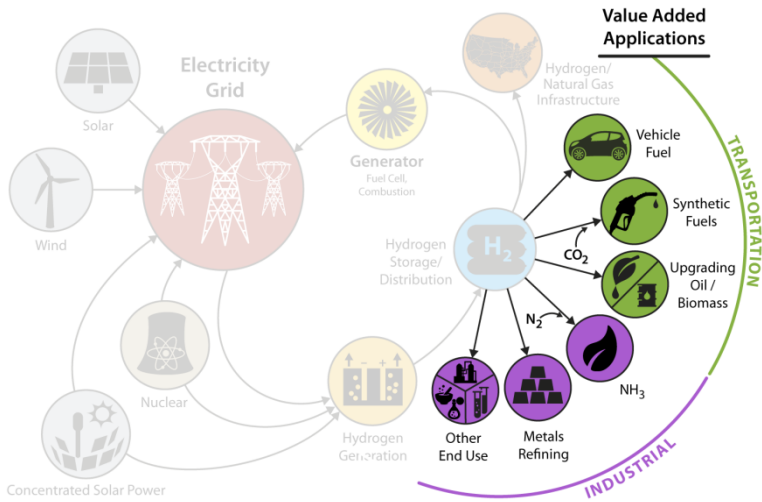

R&D Focus	Research Activities	DOE Programs	Impact
Ammonia	<ul style="list-style-type: none"> Modular Plants Catalyst R&D Process intensification Ammonia Fuel Cells 	ARPA-E AMO FCTO FE SC	<ul style="list-style-type: none"> ✓ Decrease cost of NH₃ production >25% ✓ Improve process efficiency ✓ Improve NH₃ handling safety
Refineries	<ul style="list-style-type: none"> Electrolysis and refinery heat integration H₂ and O₂ combustion Integrated coke gasification NE & RE energy utilization 	FE FCTO AMO SC NE & RE	<ul style="list-style-type: none"> ✓ >75% GHG footprint reduction ✓ Facilitate heavy crude refining ✓ Coke by-product management ✓ Expand markets for RE & NE
Chemicals	<ul style="list-style-type: none"> Catalyst R&D for H₂-dependent chemicals CO₂ reduction chemistry Process intensification Hybrid electricity/chemicals 	ARPA-E AMO SC NE & RE FCTO	<ul style="list-style-type: none"> ✓ Sustainable chemicals production ✓ Pathway to CO₂ utilization ✓ Domestic workforce with competitive manufacturing
Biofuels	<ul style="list-style-type: none"> Modular plants for distributed production H₂ (and O₂) incorporation in bio-refineries 	BETO VTO SC NE & RE FCTO	<ul style="list-style-type: none"> ✓ Increase biofuels potential production >30% ✓ 100% zero-emissions biofuels ✓ Expand markets for local RE
Metals & Glass Refining	<ul style="list-style-type: none"> Direct reduction of iron process development Metals annealing/tempering Materials codification 	ARPA-E AMO SC	<ul style="list-style-type: none"> ✓ 10x increase in U.S. steel production with associated heavy manufacturing ✓ >5% impact on world GHG
Combustion Processes	<ul style="list-style-type: none"> Flame chemistry and heat transfer studies Burner and turbine testing 	ARPA-E AMO FE SC	<ul style="list-style-type: none"> ✓ Movement toward Zero-emissions process heating ✓ Clean power generation
H2 Heat Pumps	<ul style="list-style-type: none"> Low temperature heat use Industrial and residential energy efficiency studies Power systems integration 	ARPA-E AMO BTO FE SC	<ul style="list-style-type: none"> ✓ 5% efficiency improvement for manufacturing industries ✓ 10% efficiency improvement for power generation turbines ✓ >50% cooling water reduction

QTR Connections



QTR Feedback

- **Major challenges:**

Reduce the cost of producing and delivering H₂ from renewable/low-carbon sources for FCEV and other uses (capex, O&M, feedstock, infrastructure, safety, permitting, codes/standards)

- **Factors driving change in the technologies:**

- FCEVs are driving requirements (e.g. high P tanks)
- Need to reduce cost of 700 bar refueling stations for near-term FCEV roll-out

- **Where the technology R&D needs to go:**

- Materials innovations to improve efficiencies, performance, durability and cost, and address safety (e.g. embrittlement, high pressure issues)
- System-level innovations including renewable integration schemes, tri-generation (co-produce power, heat and H₂), energy storage balance-of-plant improvements, etc.
- Cost reductions in H₂ compression, storage and dispensing components
- Continued resource assessments to identify regional solutions to cost-competitive H₂

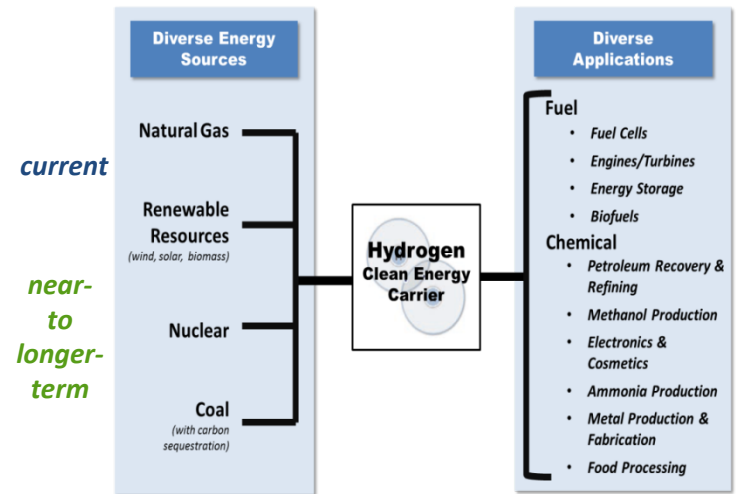

H₂ offers important long-term value as a clean energy carrier

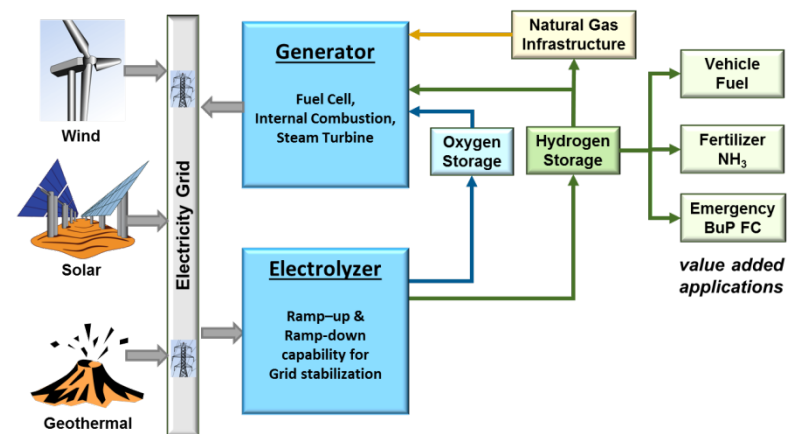

Renewable energy integration options with hydrogen

QTR - Hydrogen Analysis and Research Goals

- Reduce the cost of H₂ from renewable and low-carbon domestic resources to achieve a delivered & dispensed cost of <math>< \\$4/\text{gge}</math> (Note: 1 kg H₂ ~ 1 gge)

Pathways:

- Electrolysis, high temperature thermochemical (solar/nuclear), biomass gasification/bio-derived liquids, coal gasification with CCS, biological & photoelectrochemical

- Need R&D in materials and components to improve efficiency, performance, durability, and reduce capital and operating costs for all pathways

- For many pathways, feedstock cost is a key driver of H₂ cost

- Need strong techno-economic and regional resource analysis
- Opportunities for energy storage (e.g. curtailed wind for electrolyzing water)

• Durability and Reliability (Stack & BOP replacement)

• Labor and G&A
• Materials Replacement
• Taxes, Licenses & Permits

• Anode support
• Membrane Catalyst
• Bipolar Plates
• Cell-Separator
• Cathode Support

• Power Electronics
• Gas, Water and Thermal Management
• Controls & Sensors

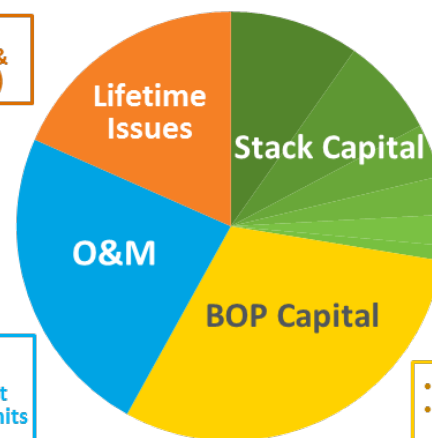

H₂ Production Example- Cost Breakdowns for PEM electrolysis, (excluding electricity feedstock costs)

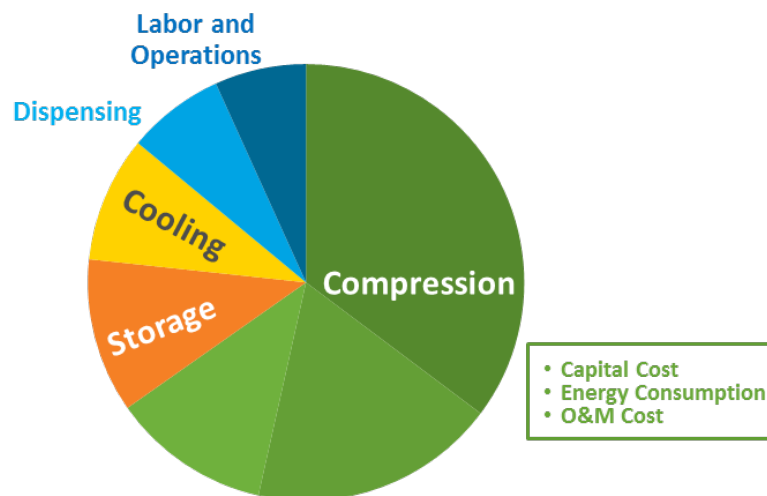

H₂ Delivery Example- Compression, Storage and Dispensing (CSD) Cost Breakdown for the Pipeline Delivery Scenario